

Fig. 118 Access to the cables

- [1] Low voltage cable inlet
- [2] Mains voltage cable inlet
- [3] HCM - Heating Control Module
- [4] Pressure gauge
- [5] Low voltage connectors
- [6] Mains voltage and earth connectors

Removing the control unit

- ▶ Support the control unit and detach the control unit support strap.
 1. Release the two catches underneath the panel.
 2. Hinge the control unit up to approximately a 45° angle.
 3. Push inwards and upwards to disengage the control unit from the hinge supports.
- ▶ Remove the support strap from the control unit.
- ▶ Fit the new control unit in the reverse order.
- ▶ Attach support strap to the new control unit.
- ▶ Fit the HCM, removed from the old control unit, into the retainer and reconnect the cable.
- ▶ Reconnect all the cables previously disconnected under the access cover.



CAUTION: Earth cables must be reconnected.

- ▶ Replace the access cover and secure with the screw.
- ▶ Reconnect the cables previously disconnected under the installer access cover.
- ▶ Replace the installer access cover and secure with the three screws removed earlier.

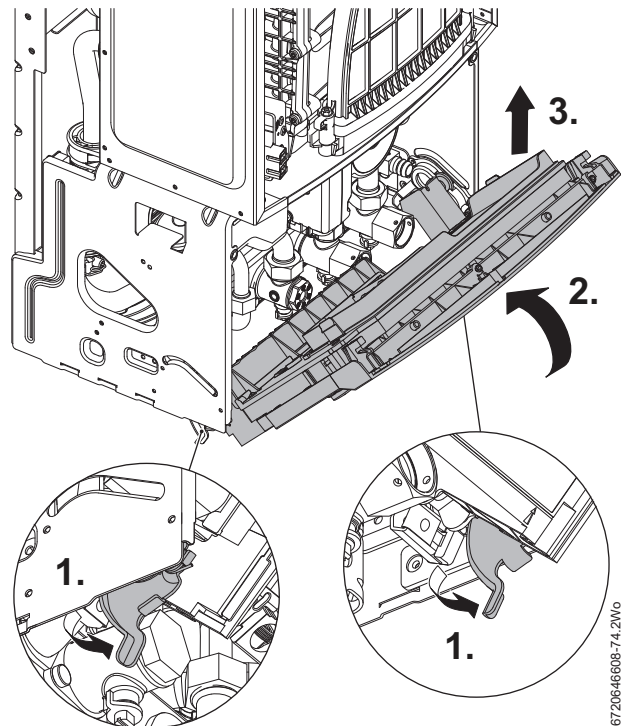

Fig. 119 Removing the controller

7.8.31 Expansion vessel

The expansion vessel can be replaced with the boiler in place if there is a side exit flue fitted and a minimum clearance of 450mm above the boiler casing.
 If a vertical flue is fitted then a similar clearance to one side of the flue is required.
 If the clearance is not available, then the boiler will need to be removed from the mounting frame to gain access to the expansion vessel.
 Alternatively, a second vessel of at least the capacity of seven litres can be fitted to the return pipe from the heating system as close as possible to the boiler.

Expansion vessel replacement (Boiler fitted)

- ▶ Isolate the power from the boiler.
- ▶ Lower the control panel into the service position.
- ▶ Isolate the boiler from the heating system using the service valves.
- ▶ Drain the boiler.
- ▶ At the pump manifold, release the clip and disconnect the expansion vessel.
- ▶ Pull the vessel up and out over the flue system or to one side if a vertical flue is fitted.
- ▶ Fit a new "O" ring to the replacement vessel and smear with silicone grease.
- ▶ Reassemble the expansion vessel into the wall frame and slide down the runners until the end pipe is reconnected into the pump manifold.
- ▶ Secure the pipe with spring clip

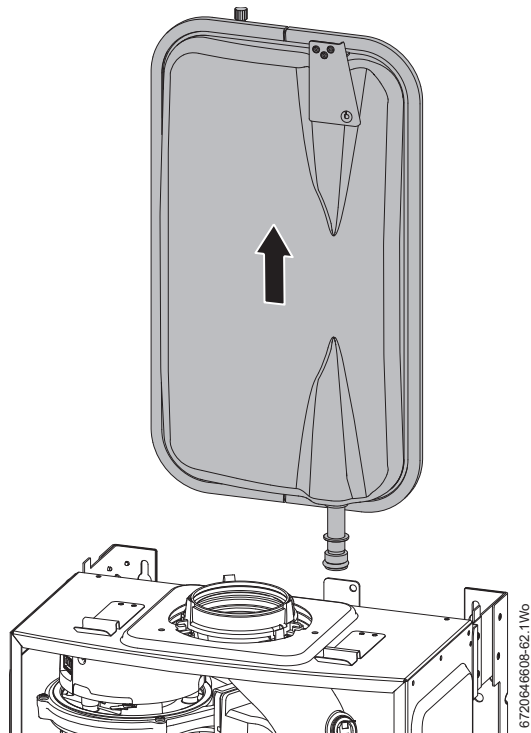

Fig. 120

Expansion vessel replacement (boiler Removed)

- ▶ Isolate the power from the boiler.
 - ▶ Isolate the heating systems and gas connection using the service valves.
 - ▶ Drain the boiler.
 - ▶ Disconnect the electrical supply and any external controls.
 - ▶ Disconnect the flue from the boiler.
 - ▶ Undo the connections to the boiler at the service valves.
 - ▶ Lower the control panel into the service position.
 - ▶ At the pump manifold, release the clip and disconnect the expansion vessel.
 - ▶ Lift the expansion vessel up to clear the pump manifold connection.
 - ▶ Secure the expansion vessel to the wall frame by the bracket at the top.
 - ▶ Undo the two screws at the bottom of the case.
 - ▶ Release the clips at the top of the case and slide the case towards you to remove.
 - ▶ Disconnect the pipes and siphon discharge hose from the plumbing manifold.
 - ▶ Disconnect the PRV.
 - ▶ Lift the boiler off the wall frame.
1. Remove the screw retaining the expansion vessel to the wall frame and lift the expansion vessel to clear the cross beam.

2. Pull the expansion vessel towards you and down to remove.

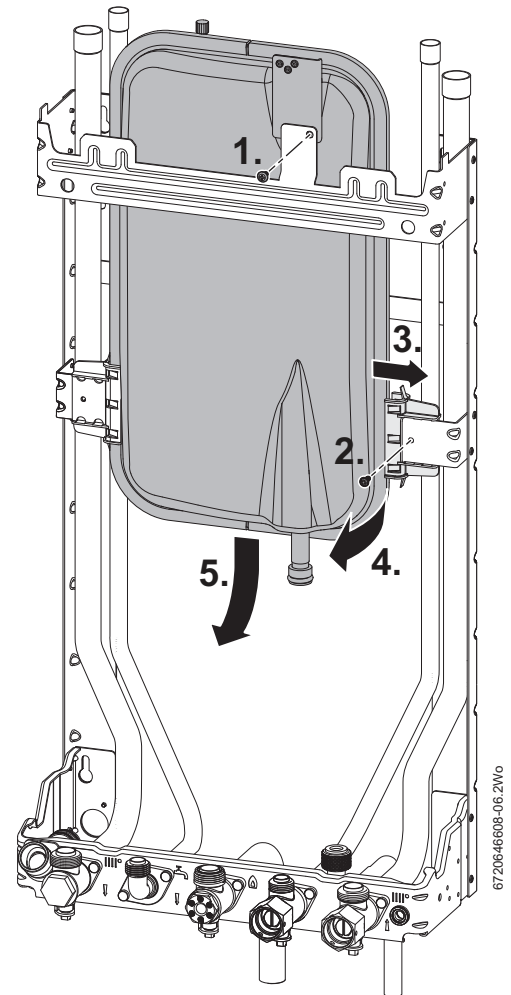
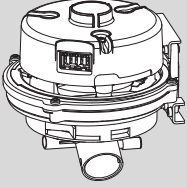
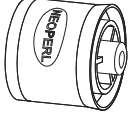
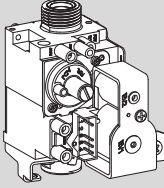
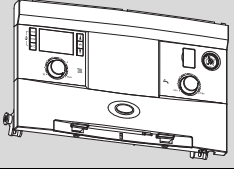
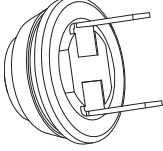
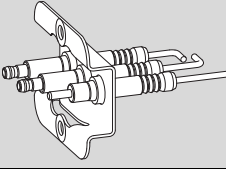
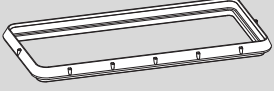
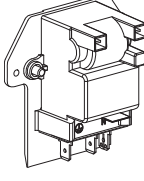
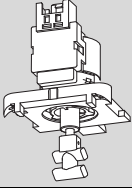
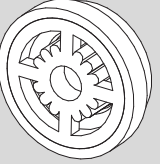
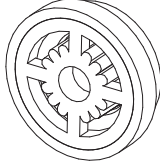
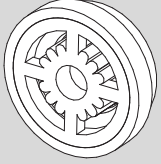
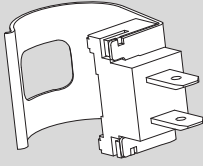
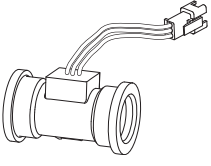
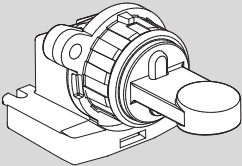
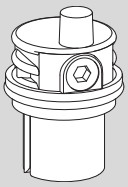
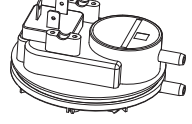
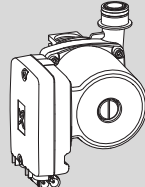
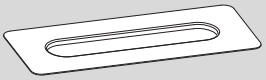
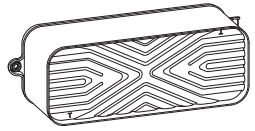
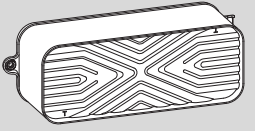

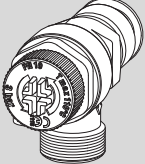
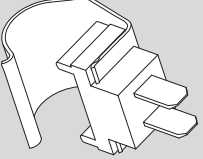

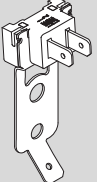

Fig. 121 Removing the expansion vessel

- ▶ Replace the expansion vessel in the reverse order.
- ▶ Follow the procedures in this manual for commissioning this product.

7.9 Short parts list

<p>Fan 8 716 117 417</p> 	<p>By pass valve 8 716 106 434 0</p> 	<p>Gas Valve 8 718 600 04A 0</p> 
<p>Control panel 8 737 909 49A 0</p> 	<p>Flue overheat thermostat 8 717 206 213 0</p> 	<p>Electrodes (including gasket) 8 718 600 28A 0</p> 
<p>Burner seal 8 718 600 24A 0</p> 	<p>Spark generator 8 716 117 077</p> 	<p>Diverter valve motor 8 718 682 839 0</p> 
<p>Flow regulator 10 litre E-W-LP Light blue 8 718 684 212 0 Used on 28CDi Compact ^{ErP}</p> 	<p>Flow regulator 11 litre E-W-LP Brown 8 718 684 213 0 Used on 32CDi Compact ^{ErP}</p> 	<p>Flow regulator 13 litre E-W-LP Olive green 8 718 688 409 0 Used on 36CDi Compact ^{ErP}</p> 
<p>Flow NTC 8 718 688 801 0</p> 	<p>Flow turbine 8 717 002 132 0</p> 	<p>Diverter valve assembly 8 716 106 845 0</p> 
<p>Auto Air Vent T 005 000 87A 0</p> 	<p>Air Pressure Switch 8 716 106 633 0</p> 	<p>Pump assembly 8 716 117 628</p> 
<p>Burner 8 718 600 23B 0</p> 	<p>Heat exchanger 18 plate 8 718 642 948 0 Used on 28CDi Compact ^{ErP}</p> 	<p>Heat exchanger 22 plate 8 718 641 238 0 Used on 32 & 36CDi Compact ^{ErP}</p> 
<p>Pressure gauge 8 718 686 513 0</p> 	<p>Expansion vessel 8 718 684 945 0</p> 	<p>Pressure relief valve 3 bar 8 718 681 163 0</p> 
<p>DHW NTC 8 716 010 809 0</p> 	<p>Return temp. sensor (NTC) 8 718 684 323 0</p> 	<p>Max safety sensor NTC 8 718 685 483 0</p> 

8 FAULT FINDING AND DIAGNOSIS

8.1 Internal wiring diagram

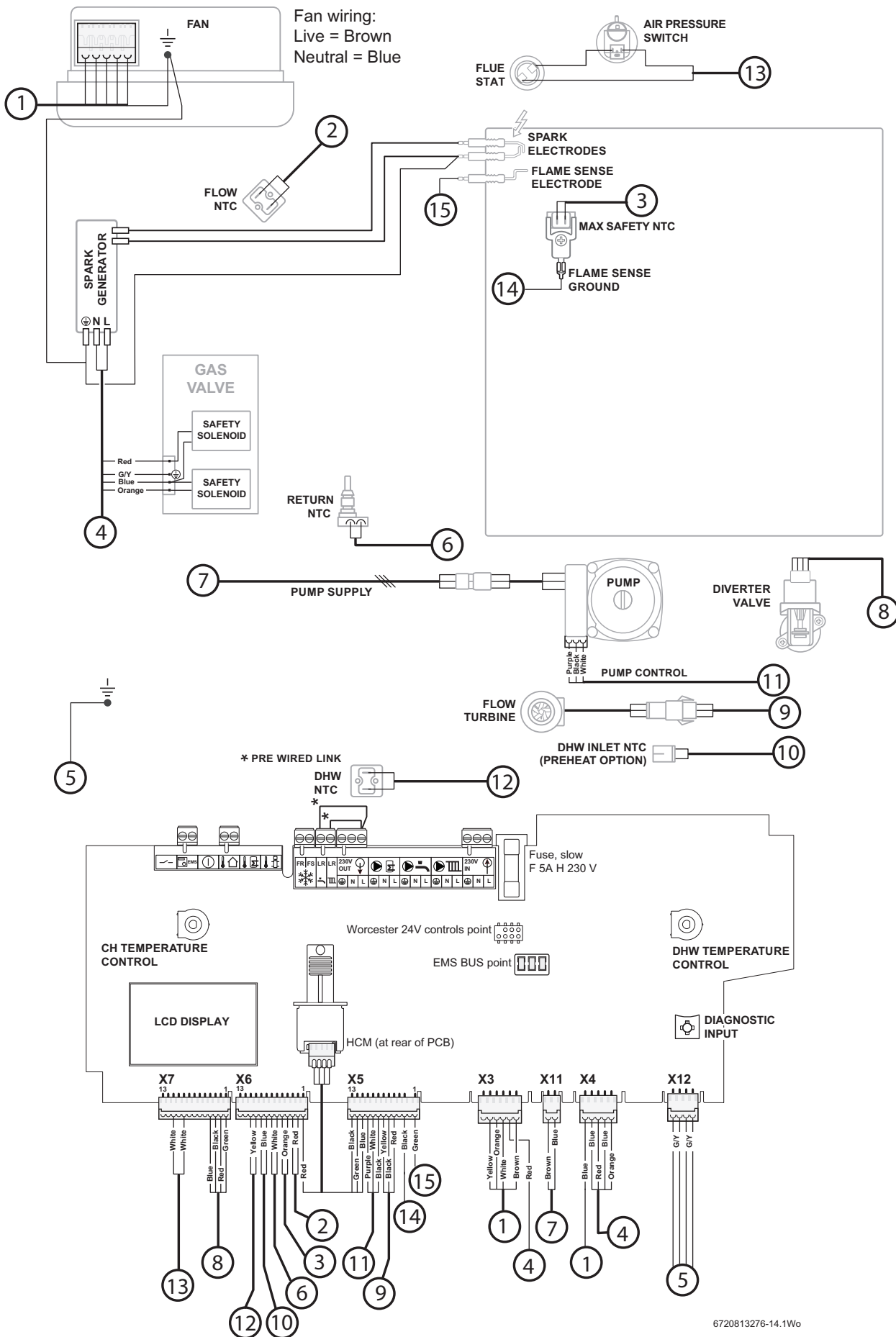

6720813276-14.1Wo

8.2 Central heating function

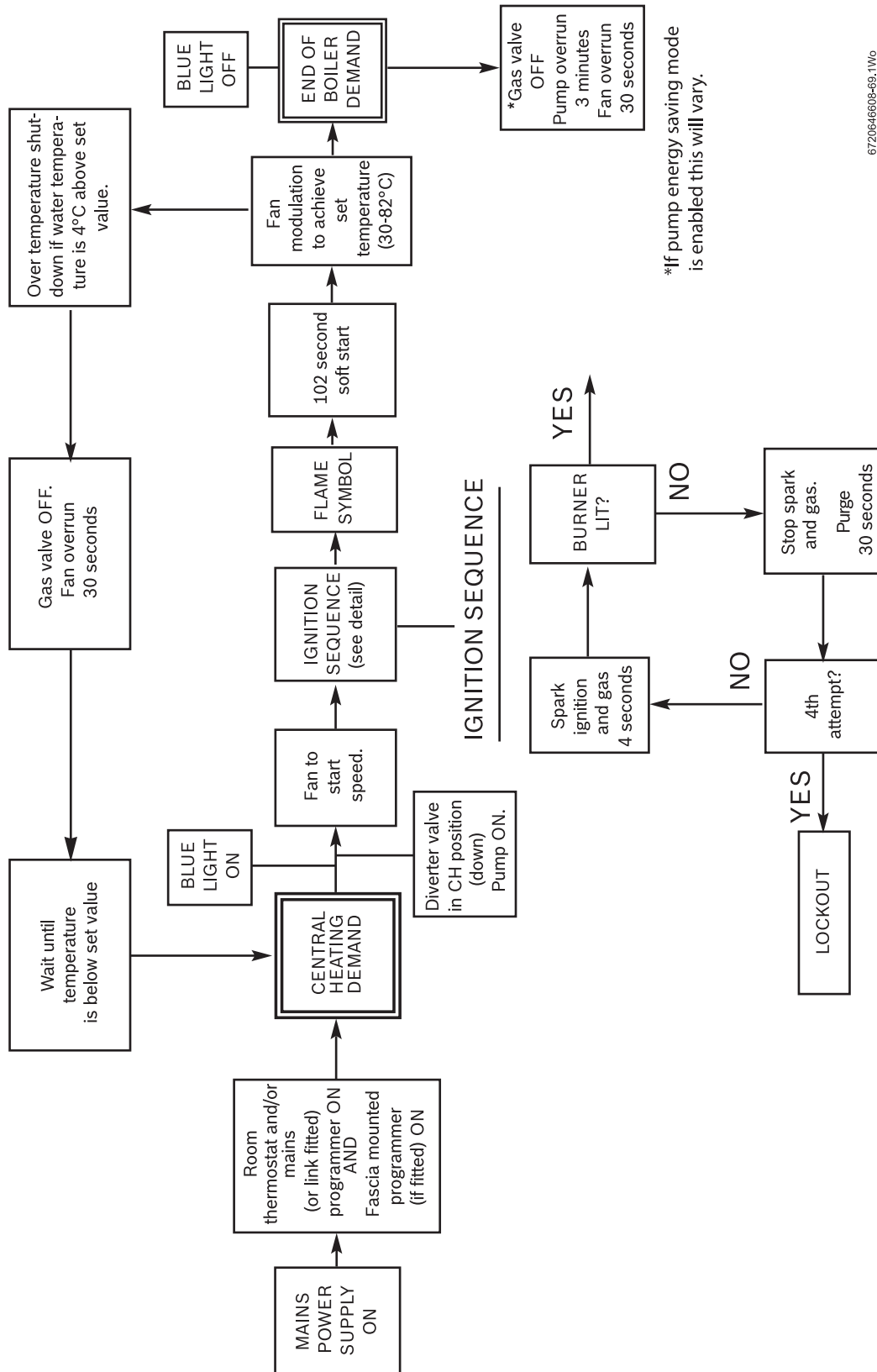

6720646808-69.1W0

Fig. 122 Central Heating function

8.3 Preheat and DHW function

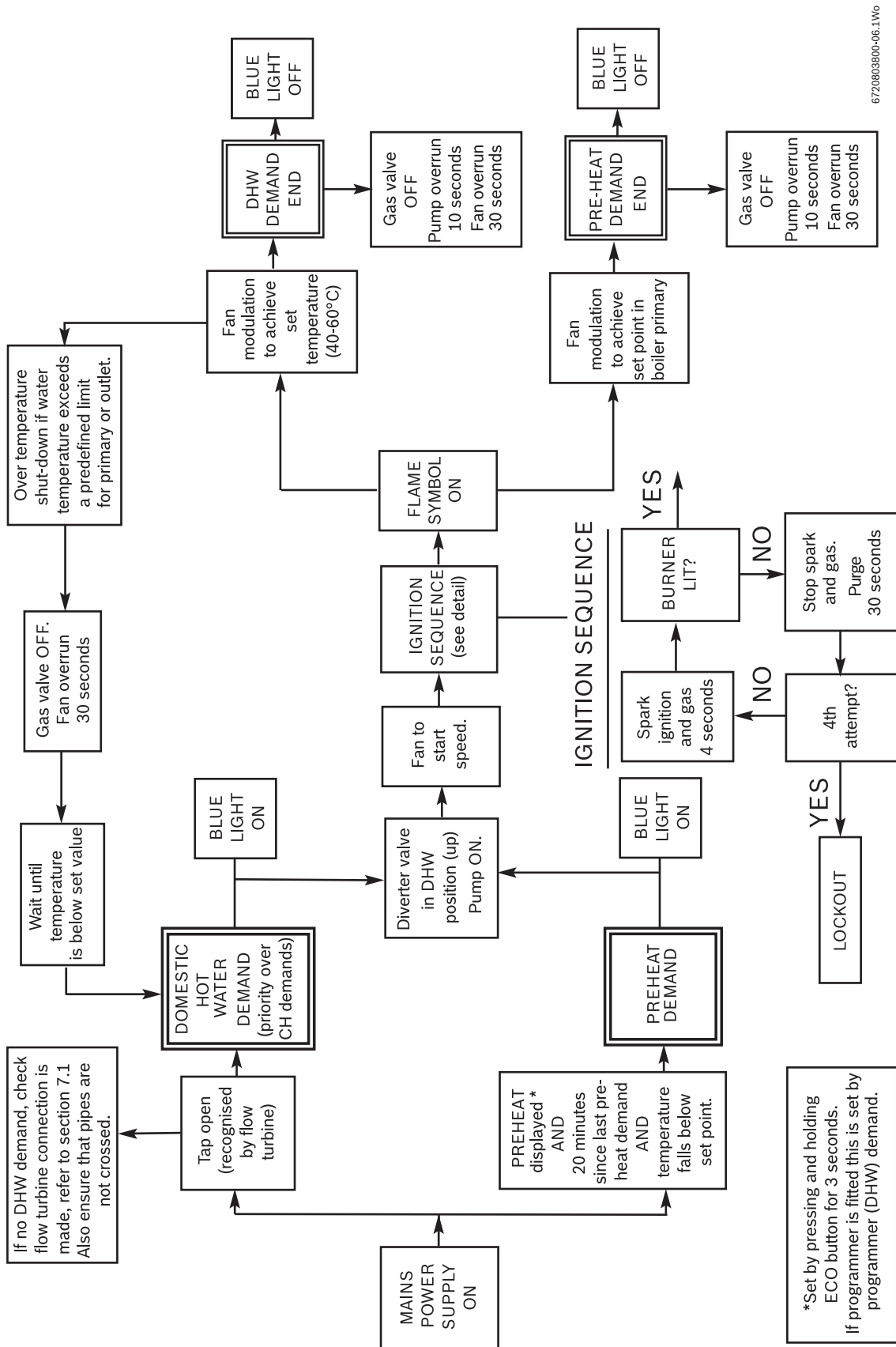
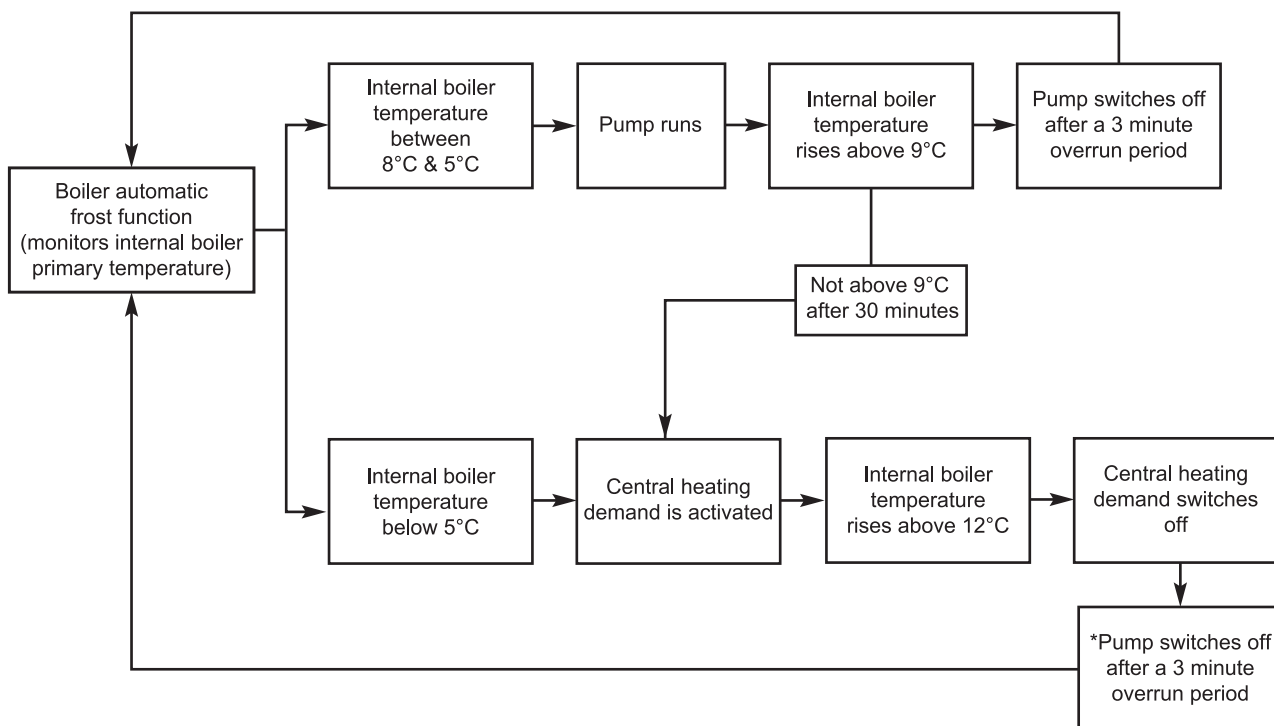

Fig. 123 PreHeat and DHW function

8.4 Protection function

AUTOMATIC INTERNAL FROST FUNCTION



PUMP OVERRUN FUNCTION CH

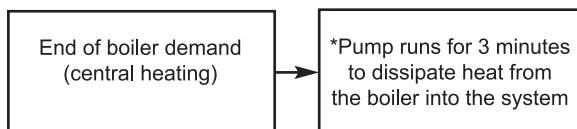

PUMP OVERRUN FUNCTION DHW

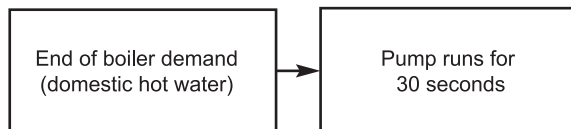

PUMP OVERRUN LOCKING ERROR

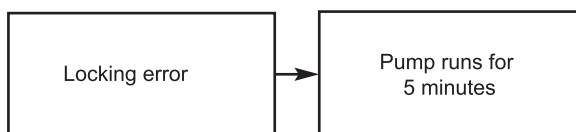

* This may vary if the Pump Energy Saving mode is enabled

PUMP ANTISEIZE FUNCTION

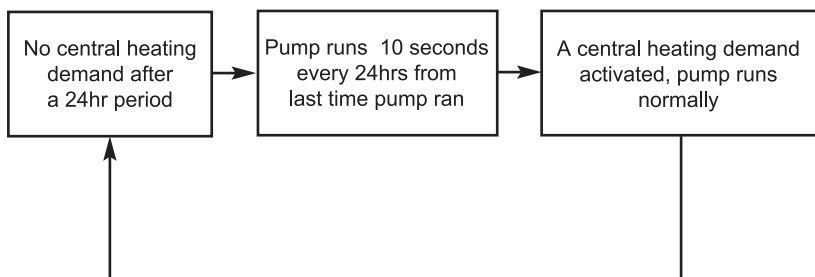

6720646608-71.1Wo

Fig. 124 Protection function

8.5 Information and service menus

STATUS CODES

During normal boiler operation various Status codes can be displayed by pressing the  button.

The first screen of the Information menu displays the current Status code, this will change as the boiler runs through the various modes and sequences.

These are not always faults, but just provide information concerning the current status of the boiler.

Status codes	Fault codes	
200		CH System is being heated
201		DHW system is being heated
202		Anti rapid cycle mode
203		System stand by
204		System waiting, primary flow temperature above setpoint
205		Waiting for airflow
207	CE	System pressure too low
208		Test mode active due chimney switch
210	E9	Flue-gas thermostat or Air pressure switch activated
211		TTB opened (thermal kickback device)
212		Safety or flow temperature rises too fast
213	D4	Temperature difference between supply and return exceeding limit
214	C7	Fan not running
215	C6	Fan running too fast
216	C6	Fan running too slow
217	C7	No airflow after defined period of time
218	E5	Flow temperature too high
219	E9	Safety sensor temperature too high
220	E9	Safety sensor shorted
221	E9	Safety sensor disconnected
222	E2	Flow sensor shorted
223	E2	Flow sensor disconnected
224	E9	MAX thermostat activated
225		Difference between flow and safety exceeding limit (bi-sensor only)
227	EA	No ionisation detected after ignition
228	F7	Ionisation current detected before burner-start
229	EA	Loss of ionisation signal during operation
230	EA	Ionisation signal out of bounds
231	FD	Mains power error - electrical power interruption
232	D3	external cut-off switch activated
233	9U	HCM problem
234	EA	Gas valve coil disconnected
237	C4	Airflow present during last 24 hours - fan running continuously
238	F0	Internal error - replace control board
239	F0	Watchdog relay error
240	D1	Return sensor shorted
241	D1	Return sensor disconnected
242 to 256	F0	Internal error call Bosch helpline 0330 123 3366
257	b7	Internal error - replace control board
258 & 259	F0	Internal error call Bosch helpline 0330 123 3366
260		No temperature rise after burner start

Status codes	Fault codes	
261	EA	First Safety timing error
262 & 263	F0	Internal error call Bosch helpline 0330 123 3366
264	C1	Airflow stopped during operation
265		Stand-by mode forced due to energy transfer limit
266	CE	No pressure variation detected after switching pump
267	F0	Watchdog time out error
268		Component test mode
269	EA	Ignition device activated too long
270		Power up mode
271	D4	Temperature difference between flow and safety sensor exceeding limit
272	F0	Internal error
273	C4	Airflow present during last 24 hours
274		Ionisation signal present during last 24 hours
276	E9	Flow temperature exceeded 95°
277	E9	Safety sensor temperature exceeded 95°
278	F0	Sensor test failed
279	F0	AD converter error, unstable measurement
280	F0	Recycle timing error
281	A1	Pump stuck or running in air
282	H5	No feedback from pump
283		Burner starting
284		Gas valve(s) opened, first safety time started
285	E9	Return temperature exceeded 95°C
286	D1	Return temperature too high
287	F0	Ionisation sensor shorted
288	CF	Water pressure sensor not connected or short-circuit to supply
289	CF	Water pressure sensor not connected or short-circuit to ground
290	F0	AD converter reference error
305		Anti fast cycle mode
306	FA	Ionisation detected after burner stop
307		Pump stuck
308		Pump running in air
309		CH & DHW system are being heated
310		CUS communication error
311		CUS locked
312		CUS blocked
313		CUS reported error condition
314		Mains disconnected during super lockout
315		Several times lack of water flow
316	E9	Flue gas sensor temperature too high
317	A3	Flue gas sensor shorted
318	E9	Flue gas sensor disconnected
321		Self-test of flue gas supervision
322		Code error
323	A8	EMS communication error
324		DHW-NTC defect
325		DHW-NTC not correctly installed
326		Storage-NTC defect
327		Reset-key stuck or short-circuit
328		Internal error
329	CE	No pressure variation detected after switching pump

Status codes	Fault codes	
332	E5	Supply sensor exceeded 110°C
333		Start temporarily not allowed due to flow error on CH
338	F0	Too many short burner starts without confirmation of water flow
341	D4	CH: supply and/or return temperatures rising too fast
342	D4	HW: supply temperature rising too fast
343	ED	CH: flue gas temperature rising but supply temperature not
344	ED	HW: flue gas temperature rising but supply temperature not
345	EF	Supply and/or return temperatures do not change after burner start
346	EC	Flue gas temperature rising too fast
347	E3	Return temperature higher than supply temperature (some time after burner start)
348	EE	HW: supply temperature too hot
349	EF	CH: Boil Detect, large delta T despite minimum burner load
350	E2	Flow sensor shorted 351 'E2' Flow sensor disconnected
353	--	Burn temporarily blocked due to no 20 minute continuous OFF time in last 24 hours.
354		Overpressure setting erased
357		Primary Heat Exchanger air venting program active - approx. 100 seconds
358		Three way valve kick
359		DHW outlet temperature too hot
364	FA	Gas valve EV2 leak test failed
365	Fb	Gas valve EV1 leak test failed
372		Temporarily ignoring CH requests to limit temperatures of the appliance components
373	8C	SuperLock caused by too frequent thermostat overheat detections during burning
374	8C	SuperLock caused by too frequent ionisation loss during burning
375	E4	Preheat sensor on DHW inlet Short Circuit
376	E4	Preheat sensor on DHW Inlet Open Circuit
380		Inlet temperature greater than DHW Outlet Set point
800	CC	Outdoor sensor defect
808	A7	Domestic hot water sensor defect
810		Domestic hot water remains cold
828		Water pressure sensor defect

8.5.1 Selecting the information menu



The Information Menu is a "read only" menu. Information about the boiler is displayed here, some of the values are updated in real time to give the current status of the boiler.

All menus time-out after two minutes and the display returns to the normal operation display, the display backlight turns off after another 30 seconds.

Double up or down arrows indicate that the menu can only be scrolled up or down, an up and down arrow combination indicates position in the menu where options can be scrolled either up or down.

To enter Information menu:

1. Press the  button to enter the information menu.
 - ▶ A three figure boiler status code will be displayed along side the information menu number. Refer to status code table on page 65 for a description of the boiler status codes.

2. Use the  and  arrow buttons to scroll through the menu items.
 - ▶ Press the  button again to exit the Information menu.

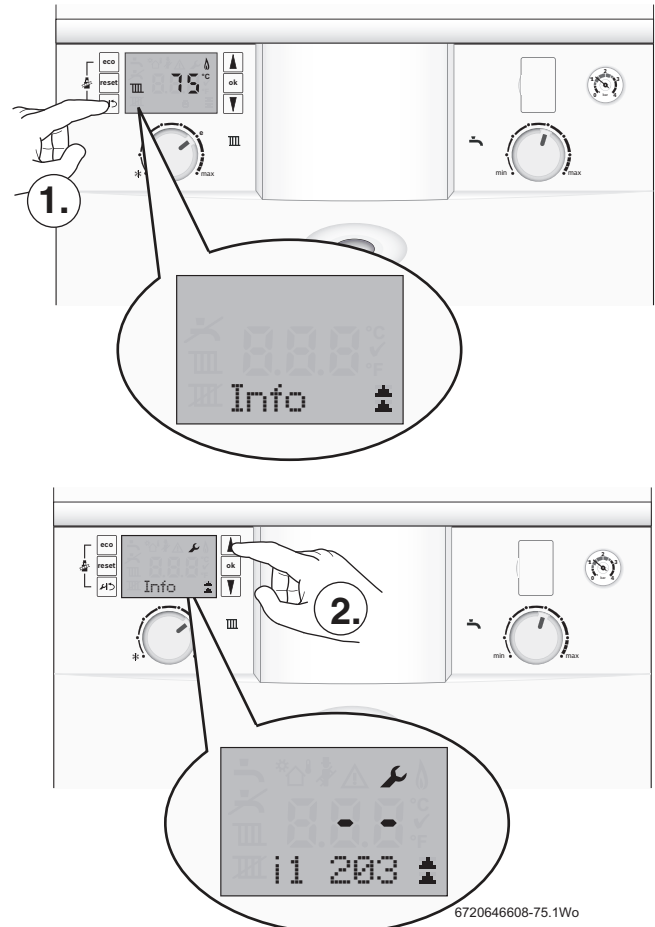

Fig. 125 Accessing the Information menu

i1	Current status	Every operation and mode of the boiler has a related boiler status code. The boiler status code is displayed on the screen as a three figure number. Refer to table on page 65 or error table for information on the boiler status codes.
i2	Last error	This can be viewed during normal operation. Displays the last diagnostic code with boiler status code.
i3	Maximum heating output	The maximum possible heat output is displayed in kW. The boiler may have the maximum output reduced via Menu 3.1A
i6	DHW flow rate at 40 °C temp. rise ± 15%.	The screen displays the current DHW flow rate in litres per minute to one decimal place.
i7	Supply temperature setpoint	This is the temperature set point for the primary flow from the main heat exchanger. (This will be zero during HW demand.)
i8	Ionization current	The ionization current should be equal to or greater than 35 µA (micro Amps) when boiler is at maximum rate.
i9	Flow temperature	This is the actual temperature from the main heat exchanger displayed in real time.

Table 29 Information menu listing

i10	Maximum temperature	This is the current temperature from the "Maximum safety sensor". This sensor is mounted on the front of the heat exchanger.
i11	DHW flow temperature	The current DHW flow temperature.
i12	DHW temperature setpoint	This is the temperature selected via the Hot Water control knob on the fascia.
i14	Return temperature	The current temperature returned to the main heat exchanger.
i15	Outdoor temperature	Optional outdoor temperature sensor needs to be connected for this menu to be activated.
i16	Pump modulation	The current pump modulation is displayed as a percentage.
i17	Burner modulation	The current burner modulation is displayed as a percentage.
i18	Fan speed	The current fan speed is displayed in Hertz. The value is up-dated in real time.
i19	Time inputs	This indicates the status of the optional fascia mounted controls: 0 = CH off, DHW off 1 = CH off, DHW on 2 = CH on, DHW off 3 = CH on, DHW on
i20	Software version	Firmware version of the main control board.
i21	Software version	Firmware version of the fascia control display board
i22	Heat Control Module (HCM) number.	The last three digits of the HCM are displayed: 584 = 28kW Combi N.G. 585 = 28kW Combi L.P.G. 582 = 32kW Combi N.G. 583 = 32kW Combi L.P.G. 580 = 36kW Combi N.G. 581 = 36kW Combi L.P.G.
i23	Heat Control Module (HCM) version number.	For example "4"

Table 29 Information menu listing

8.5.2 Selecting service menus

1. Press and hold and buttons together for one second, the display will show Menu 1.

Double up or down arrows indicate that the menu can only be scrolled up or down, an up and down arrow combination indicates position in the menu where options can be scrolled either up or down.

2. Scroll up and down through the menus with the and buttons on the right hand side of display.

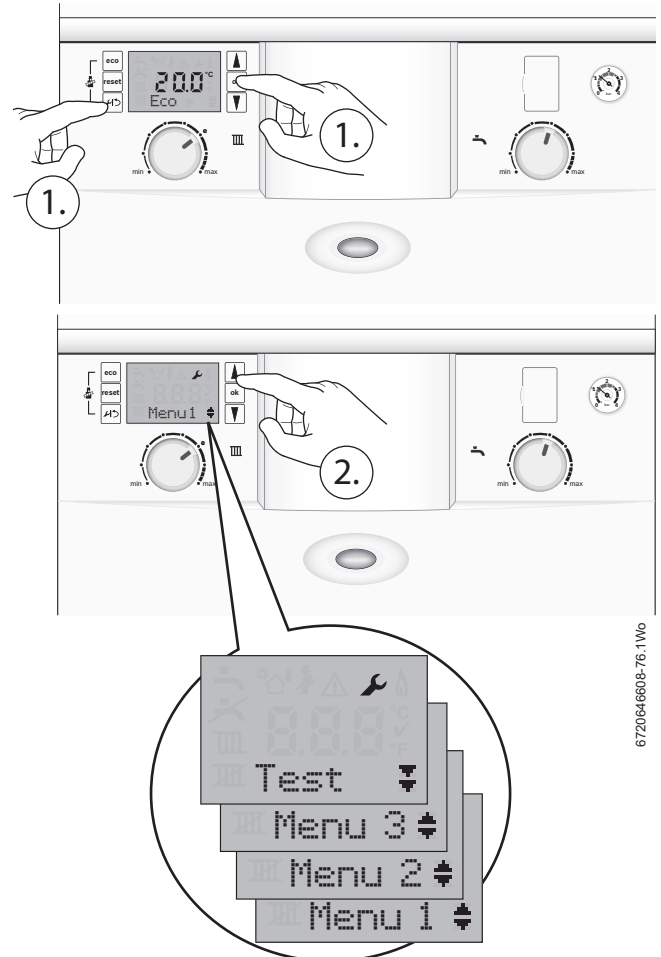

6720646608-76.1W0

Fig. 126 Service menu selection

8.5.3 Menu 1 - System parameters

Not applicable for Greenstar CDi Compact ^{ErP}

Initially Menu 1 will be displayed, but will contain no options.

8.5.4 Menu 2 - Boiler parameters

1. Select Menu 2 via the and scroll buttons.
2. Press and hold the button for one second to enter Menu 2.

This menu lists the boiler parameters, which can be adjusted in this menu.

To modify setting, select the desired menu option (refer to table 30) and press the button, the option will flash.

Adjust the parameter using the and arrow buttons and press the button to confirm.

A will display for three seconds to confirm the update of the new value.

If the setting is confirmed please record the saved value in the empty box next to the relevant setting in Table 30.

The same process is used for adjusting all Menus 1, 2, 3 and Test.

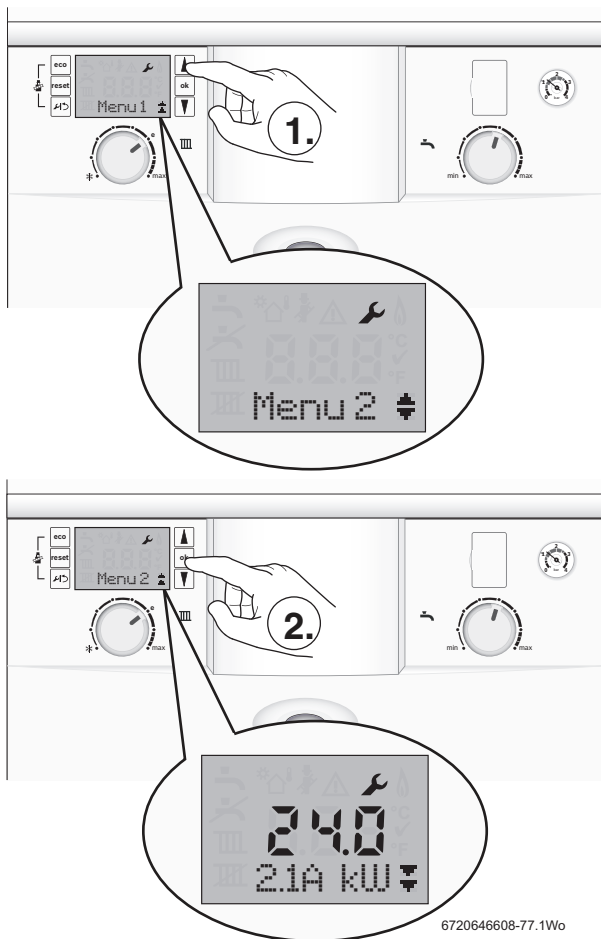

Fig. 127 Menu 2 selection

Para No.	Parameter	Description	Updated value
2.1A	Maximum power CH	Range rate the CH of the boiler. Adjustment in kW. The maximum is 24kW.	
2.1C	Pump head selection	Select the right pump map (load and modulation percentage) to suit the property. 0 = Variable speed setting 1 to 4 option pump maps	
2.1E	Pump energy saving mode	4 = mode ON, 5 = mode OFF	
2.1H	Minimum pump speed (pump speed at maximum CH burner load)	This parameter is only visible when 2.1C is set to 0. Then the min.pump speed can be set.	
2.1J	Maximum pump speed (pump speed at maximum burner load)	This parameter is only visible when 2.1C is set to 0. Then the max.pump speed can be set.	
2.2C	Air purge mode	This feature can be selected to purge the system and boiler of air. 0 = off, 1 = auto, 2 = on	
2.3B	Anti fast cycle time for CH	This sets the amount of time between stop and starts of the main heat exchanger. The default is 5 minutes, the range is 3 to 45 minutes.	

Table 30 Menu 2 parameters

Para No.	Parameter	Description	Updated value
2.3C	Anti fast cycle flow temperature hysteresis (negative tolerance only)	This sets the temperature drop before the burner re-starts, 6°K is the default. This is used in conjunction with the “Anti fast cycle time” The range is from 2 to 15°K in 1°K steps.	
2.3F	CH delay after DHW demand	The default time is 1 minute and can be adjusted to be between 0 and 30 minutes. This feature helps to keep the DHW heat exchanger hot if frequent demands are made. The boiler will not burn extra gas. CH will not be heated during this set time period.	
2.5F	Service reminder time	Between 1 and 72 months can be set	
2.7A	Operation/fault indicator (blue light) activation	0 = The blue light will only operate as a flashing fault alert. 1 = The blue light will operate as a boiler operation and fault alert. This is set to 1 by default.	
2.9E	Turbine signal delay	Delay time set to ignore a temporary DHW demand. Maximum delay is three seconds which can be set in ¼ second increments, e.g. 0.5 seconds is displayed as 2 or 1 second as 4.	
2.9F	Pump post purge time for CH	The default pump overrun time is 3 minutes. This can set between 3 and 30 minutes. The actual time will be affected by the Pump Energy Saving mode.	

Table 30 Menu 2 parameters

8.5.5 Reset to factory settings

To reset any or all changes made in menu 2 back to the factory defaults setting:

NOTICE: Menu 3
 ▶ Any changes made in Menu 3 are not reset via these actions.

1. Press and hold the , and for at least five seconds.
The screen will then display code 8E with the spanner symbol.
2. Press the button and "Reset" will be displayed with the tick symbol for three seconds.
After three seconds the screen will revert to the normal operation screen.

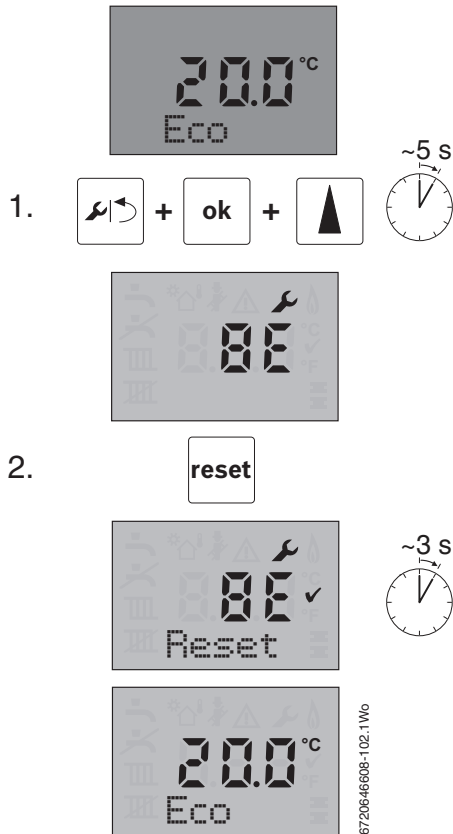

Fig. 128 Reset sequence

8.5.6 Menu 3 - Boiler maximum & minimum limits

The menu shows the boiler's minimum and maximum limits. Which can be adjusted in this menu.

The boiler will revert to adjusted settings in Menu 3 following a power interruption.

Menu 3 cannot be factory re-set.

1. Select menu 3 via the and scroll buttons.
2. Press and hold the button for at least 5 seconds to enter Menu 3.

To modify setting, select desired menu option (refer to table 31) via the and arrow buttons and press the OK button, the option will flash.

Adjust the parameters using the and arrow buttons and press the OK button to confirm.

A symbol will be displayed for three seconds to confirm the update of the new value.

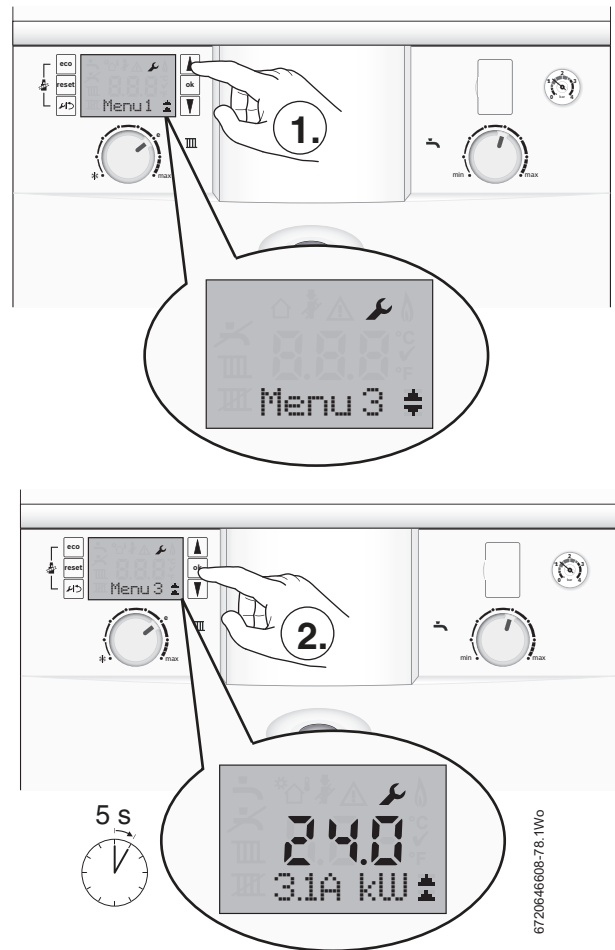

Fig. 129 Menu 3 selection

3.1A	Maximum heating output	The maximum heating output in kW can be set here. The output can be down rated. Note: When maximum boiler output is required for CO/CO ₂ testing, this parameter is ignored and full power is delivered for the duration of the test.
3.2B	Maximum flow temperature	This limits the upper flow temperature of the central heating knob. Which is 82°C as a maximum. This can be down rated.
3.3D	Minimum boiler power for both heating and hot water.	This sets the minimum output, for example 7kW.

Table 31 Menu 3 parameters

8.5.7 Using the test menu

This menu enables the testing of the functionality of components in an ON/OFF mode. The duration of each test is up to 60 seconds.

1. Select menu TEST via the and scroll buttons.
2. Press the button for one second to enter TEST.

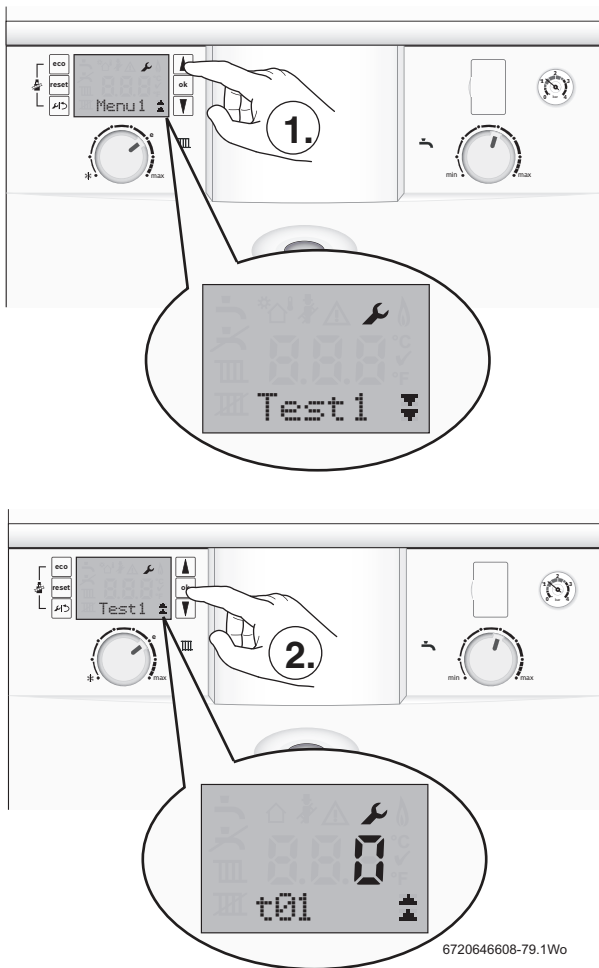

Fig. 130 Selecting test menu

Selecting a test component

Refer to table 32 and use the ▲ and ▼ arrow buttons to scroll through the various test options.

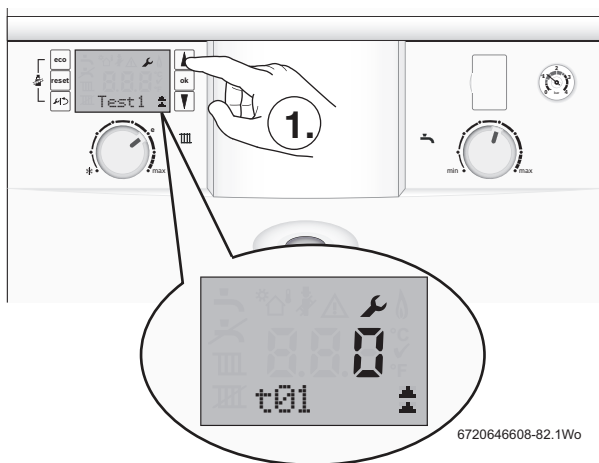

Fig. 131 Scroll through test options

Testing the component

- ▶ Select a component to test.
- ▶ Press the **ok** button, the value 0 will flash.
- ▶ Use the ▲ arrow button to change the value to a flashing 1.
- ▶ Press **ok** to confirm the change, the value 1 will stop flashing and a ✓ will displayed for 3 seconds.

The test will run for 30 to 60 seconds unless the value is changed back to 0 before that time, the test may take 10 seconds to start.

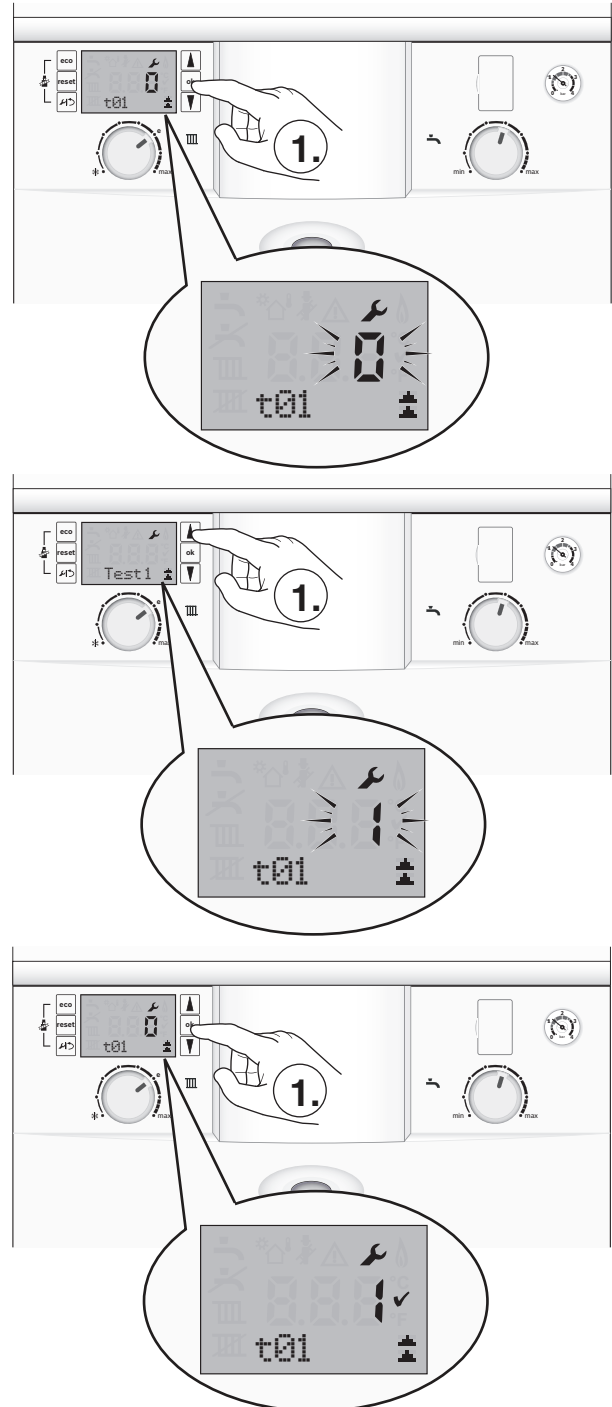

Fig. 132 Testing component

Resetting the test component

After completing the test:

- ▶ Press the **ok** button, the value 1 will flash.
- ▶ Press the ▼ arrow button, the value will change to a flashing 0.
- ▶ Press **ok** to confirm the change, a ✓ will display for 3 seconds.

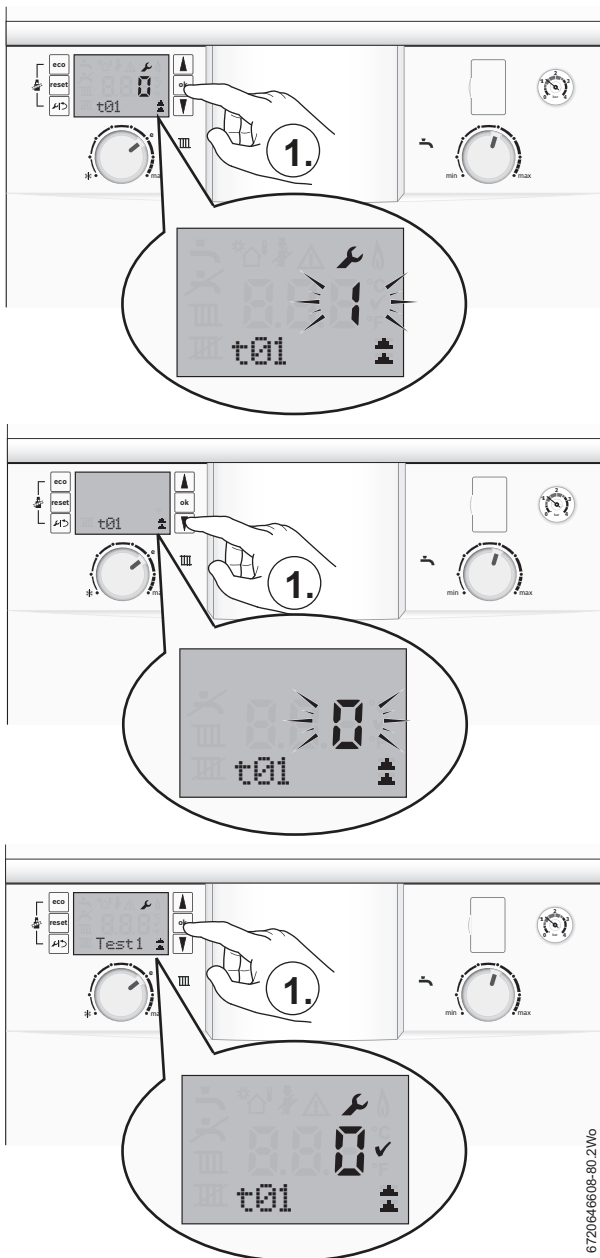

Fig. 133 Resetting test

Note that it could be up to 10 seconds after the button is pressed before the selected component responds.	
t1	Igniter test. Checking the igniter spark.
t2	Fan test. Checking the basic fan operation.
t3	Pump test. Checking the basic pump operation.
t4	Three way valve test. Test the operation of the diverter valve.
t6	Ionisation oscillator test. Tests the flame detection circuit.

Table 32 Test menu

8.6 Fault codes

Should a fault develop with this boiler (or the system), the boiler will enter a locking or blocking condition, and fault code information will be generated as described in this section.

Locking error	The boiler display will flash a warning triangle and fault code. At the same time a (static) cause code will also be displayed. Manual intervention is required following clearance of the fault: ▶ Press the reset button on the boiler fascia
Blocking error	The boiler will stop operating with no fault data displayed. The cause code, in the info menu, is accessed by pressing the spanner/return button. The condition will clear automatically when the associated fault clears e.g. waiting for an area to cool. In some cases a blocking error has a defined time duration prior to changing to a locking condition.
Fault code	Alpha numeric number indicating the fault group
Cause code	Three digit number. During a blocking error (or normal operating status) it is not displayed, but accessed in the info menu via the spanner/return button. During a locking error the cause code flashes on the display.

Locking errors

Fault codes	Cause codes	Description	Reset type	Possible cause
9U	233	HCM (Heat Control Module)	Reset button	Problem with the code plug
b7	257	Internal error		Replace control board.
C6	215	Fan problem	Reset button	Fan running too fast
	216	Fan problem	Reset button	Fan running too slow
C7	214	Fan problem	Reset button	Fan not running
	217	No airflow after a defined period of time	Reset button	Fan not running or airflow blocked
D1	240	Return sensor error	Reset button	Sensor wet or damaged (the boiler will block for 300 secs before this condition).
	241	Return sensor error	Reset button	Sensor disconnected or damaged (the boiler will block for 300 secs before this condition).
	286	Return temperature too high	Reset button	Boiler overheat
E2	222	Flow sensor short circuit	Reset button	Flow sensor shorted or damaged.
	223	Flow sensor open circuit	Reset button	Flow sensor disconnected or damaged.
E5	218	Flow temperature too high	Reset button	Primary flow sensor overheated
	332	Primary flow sensor has exceeded 110°C	Reset button	Primary flow sensor overheated
E9	219	Safety sensor temperature too high	Reset button	The main heat exchanger has overheated. Maximum temperature 105C°
	220	Safety sensor short circuit	Reset button	Maximum temperature sensor on the main heat exchanger has failed.
	221	Safety sensor open circuit	Reset button	Maximum temperature sensor on the main heat exchanger has not been recognised.
	224	Max temperature thermostat activated	Reset button	Flue gas thermostat overheat
EA	227	No flame detected after ignition	Reset button	Failure of four ignition attempts. The boiler waits 30 seconds before another attempt is made.
	229	Loss of flame signal during operation	Reset button	An established flame has been extinguished. This could be caused by: • moisture in the sump, due to a blocked sump/condensate trap. • a strong wind into the flue.
	234	Gas valve error	Reset button	Gas valve coil disconnected
	261	Ignition timing error	Reset button	Flame not established during the first 4 seconds ignition period.

Table 33 Locking fault and cause code listing

Fault codes	Cause codes	Description	Reset type	Possible cause
F0	237 - 239 242 - 256 258 259 262 263 267 272 279 290	Internal error		Call Worcester, Bosch Group Technical helpline 0330 123 3366
	278	Sensor test failed	Reset button	On power up all safety sensors are checked. Check has failed.
	280	Recycle time error	Reset button	After the burner has stopped, the recycle mode purges gas from the heat exchanger before attempting to burn again. The software has 3.1 seconds to intervene before the boiler goes into this fault condition.
	338	Too many short burner starts without confirmation	Reset button	There is an error where the pump is not detecting water.
F7	228	Flame error	Reset button	False flame. Flame detected before burner start.
	328	Internal error		Replace control board
FA	306	False flame error	Reset button	Flame detected after burner stop
FD	231	Mains power error	Reset button	Electrical power interruption.
FA	364	Gas valve EV2 leak test failed	Reset button	Gas valve leak.
Fb	365	Gas valve EV1 leak test failed	Reset button	Gas valve leak.

Table 33 Locking fault and cause code listing

Blocking errors

Fault code	Cause code	Description	Possible cause
A1	281	Pump stuck or running in air	Little or no water in the system.
C1	264	Airflow stopped during operation	Fan has stopped.
C4	273	Airflow present during last 24 hours	Fan has been running continuously during the past 24 hours.
D1	240	Return sensor short circuit	Wet sensor. Blocking for 300 secs before going to Locking error (→ table 33).
	241	Return sensor disconnected	Blocking for 300 secs before going to Locking error (→ table 33).
D4	271	Temperature difference between flow and safety sensors exceeds limit	The temperature of the primary flow and the safety sensor on the WB7 should be within 15°C of each other.
E9	224	MAX thermostat activated	Flue gas thermostat overheat.
	276	Flow temperature exceeds 95°C	Primary overheat - boiler waits for temperature to reduce; if not it becomes a Locking error.
	277	Safety temperature exceeds 95°C	Main heat exchanger safety sensor overheat - boiler will wait for the temperature to reduce; if not it becomes a Locking error 219.
	285	Return temperature exceeds 95°C	The boiler will stop the burn and wait to see if it cools down. If after 2 seconds there is an increase in temperature the boiler will go to Locking error 286.
EA	227	No ionisation detected after ignition	No flame is detected. The boiler will block during 4 attempts before going to Locking fault.
EF	349	Central heating, boil detect. Large delta T despite minimum burner.	The boiler is operating at minimum burner load and there is a greater than 18°C Flow & Return temperature difference.
No code	212	Safety or flow temperature rises too fast	Air lock or reduced water content.
	213	Temperature difference between supply and return exceeding limit	Air lock or reduced water content.
	260	No temperature rise after burner starts	Sensor disconnected or no water content.
	380	Inlet DHW temperature higher than the DHW outlet temperature.	The output is blocked until the inlet temperature drops below the output temperature.

Table 34 Blocking codes

GAS BOILER SYSTEM COMMISSIONING CHECKLIST

This Commissioning Checklist is to be completed in full by the competent person who commissioned the boiler as a means of demonstrating compliance with the appropriate Building Regulations and then handed to the customer to keep for future reference.

Failure to install and commission according to the manufacturer's instructions and complete this Benchmark Commissioning Checklist will invalidate the warranty. This does not affect the customer's statutory rights.

Customer name:	Telephone number:
Address:	
Boiler make and model:	
Boiler serial number:	
Commissioned by (PRINT NAME):	Gas Safe register number:
Company name:	Telephone number:
Company address:	
Commissioning date:	
To be completed by the customer on receipt of a Building Regulations Compliance Certificate*	
Building Regulations Notification Number (if applicable):	

CONTROLS (tick the appropriate boxes)			
Time and temperature control to heating	Room thermostat and programmer/timer Load/weather compensation		Programmable room thermostat Optimum start control
Time and temperature control to hot water	Cylinder thermostat and programmer/timer		Combination Boiler
Heating zone valves	Fitted		Not required
Hot water zone valves	Fitted		Not required
Thermostatic radiator valves	Fitted		Not required
Automatic bypass to system	Fitted		Not required
Boiler interlock			Provided

ALL SYSTEMS			
The system has been flushed and cleaned in accordance with BS7593 and boiler manufacturer's instructions			Yes
What system cleaner was used?			
What inhibitor was used?			Quantity litres
Has a primary water system filter been installed?			Yes No

CENTRAL HEATING MODE measure and record:			
Gas rate	m ³ /hr	OR	ft ³ /hr
Burner operating pressure (if applicable)	mbar	OR Gas inlet pressure	mbar
Central heating flow temperature			°C
Central heating return temperature			°C

COMBINATION BOILERS ONLY			
Is the installation in a hard water area (above 200ppm)?			Yes No
If yes, and if required by the manufacturer, has a water scale reducer been fitted?			Yes No
What type of scale reducer has been fitted?			

DOMESTIC HOT WATER MODE Measure and Record:			
Gas rate	m ³ /hr	OR	ft ³ /hr
Burner operating pressure (at maximum rate)	mbar	OR Gas inlet pressure at maximum rate	mbar
Cold water inlet temperature			°C
Hot water has been checked at all outlets			Yes Temperature °C
Water flow rate			l/min

CONDENSING BOILERS ONLY	
The condensate drain has been installed in accordance with the manufacturer's instructions and/or BS5546/BS6798	
Yes	

ALL INSTALLATIONS					
Record the following:	At max. rate:	CO	ppm	AND	CO/CO ₂ Ratio
	At min. rate: (where possible)	CO	ppm	AND	CO/CO ₂ Ratio
The heating and hot water system complies with the appropriate Building Regulations					Yes
The boiler and associated products have been installed and commissioned in accordance with the manufacturer's instructions					Yes
The operation of the boiler and system controls have been demonstrated to and understood by the customer					Yes
The manufacturer's literature, including Benchmark Checklist and Service Record, has been explained and left with the customer					Yes

Commissioning Engineer's Signature
Customer's Signature
(To confirm satisfactory demonstration and receipt of manufacturer's literature)

*All installations in England and Wales must be notified to Local Authority Building Control (LABC) either directly or through a Competent Persons Scheme. A Building Regulations Compliance Certificate will then be issued to the customer.



SERVICE RECORD

It is recommended that your heating system is serviced regularly and that the appropriate Service Interval Record is completed.

Service Provider

Before completing the appropriate Service Record below, please ensure you have carried out the service as described in the manufacturer's instructions. Always use the manufacturer's specified spare part when replacing controls.

SERVICE 01					Date:
Engineer name:					
Company name:					
Telephone No:					
Gas safe register No:					
Record:	At max. rate:	CO	ppm	AND	CO ₂ %
	At min. rate: (Where Possible)	CO	ppm	AND	CO ₂ %
Comments:					
Signature					

SERVICE 02					Date:
Engineer name:					
Company name:					
Telephone No:					
Gas safe register No:					
Record:	At max. rate:	CO	ppm	AND	CO ₂ %
	At min. rate: (Where Possible)	CO	ppm	AND	CO ₂ %
Comments:					
Signature					

SERVICE 03					Date:
Engineer name:					
Company name:					
Telephone No:					
Gas safe register No:					
Record:	At max. rate:	CO	ppm	AND	CO ₂ %
	At min. rate: (Where Possible)	CO	ppm	AND	CO ₂ %
Comments:					
Signature					

SERVICE 04					Date:
Engineer name:					
Company name:					
Telephone No:					
Gas safe register No:					
Record:	At max. rate:	CO	ppm	AND	CO ₂ %
	At min. rate: (Where Possible)	CO	ppm	AND	CO ₂ %
Comments:					
Signature					

SERVICE 05					Date:
Engineer name:					
Company name:					
Telephone No:					
Gas safe register No:					
Record:	At max. rate:	CO	ppm	AND	CO ₂ %
	At min. rate: (Where Possible)	CO	ppm	AND	CO ₂ %
Comments:					
Signature					

SERVICE 06					Date:
Engineer name:					
Company name:					
Telephone No:					
Gas safe register No:					
Record:	At max. rate:	CO	ppm	AND	CO ₂ %
	At min. rate: (Where Possible)	CO	ppm	AND	CO ₂ %
Comments:					
Signature					

SERVICE 07					Date:
Engineer name:					
Company name:					
Telephone No:					
Gas safe register No:					
Record:	At max. rate:	CO	ppm	AND	CO ₂ %
	At min. rate: (Where Possible)	CO	ppm	AND	CO ₂ %
Comments:					
Signature					

SERVICE 08					Date:
Engineer name:					
Company name:					
Telephone No:					
Gas safe register No:					
Record:	At max. rate:	CO	ppm	AND	CO ₂ %
	At min. rate: (Where Possible)	CO	ppm	AND	CO ₂ %
Comments:					
Signature					

SERVICE 09					Date:
Engineer name:					
Company name:					
Telephone No:					
Gas safe register No:					
Record:	At max. rate:	CO	ppm	AND	CO ₂ %
	At min. rate: (Where Possible)	CO	ppm	AND	CO ₂ %
Comments:					
Signature					

SERVICE 10					Date:
Engineer name:					
Company name:					
Telephone No:					
Gas safe register No:					
Record:	At max. rate:	CO	ppm	AND	CO ₂ %
	At min. rate: (Where Possible)	CO	ppm	AND	CO ₂ %
Comments:					
Signature					

*All installations in England and Wales must be notified to Local Authority Building Control (LABC) either directly or through a Competent Persons Scheme. A Building Regulations Compliance Certificate will then be issued to the customer.



Worcester, Bosch Group
Cotswold Way, Warndon, Worcester WR4 9SW.
Tel. 0330 123 9559

Worcester, Bosch Group is a brand name of Bosch Thermotechnology Ltd.
worcester-bosch.co.uk

6 720 813 276 (2015/07)

WORCESTER, BOSCH GROUP:

TECHNICAL SUPPORT:	0330 123 3366
APPOINTMENTS:	0330 123 9339
SPARES:	0330 123 9779
LITERATURE:	0330 123 9119
TRAINING:	0330 123 0166
SALES:	0330 123 9669



WORCESTER
Bosch Group