

INSTALLATION, COMMISSIONING, AND SERVICING INSTRUCTIONS

WALL HUNG RSF GAS FIRED CONDENSING COMBINATION BOILER

Greenstar CDi Compact ^{ErP}

FOR SEALED CENTRAL HEATING SYSTEMS AND MAINS FED DOMESTIC HOT WATER



**These appliances are for use with:
Natural Gas or L.P.G.
(Cat. II 2H 3P type C13, C33 & C53)**

	Model	GC Number
Natural Gas	28CDi Compact ^{ErP}	47-406-77
	32CDi Compact ^{ErP}	47-406-79
	36CDi Compact ^{ErP}	47-406-81
LPG	28CDi Compact ^{ErP}	47-406-78
	32CDi Compact ^{ErP}	47-406-80
	36CDi Compact ^{ErP}	47-406-82

If you smell gas:

- ▶ Well away from the building: call the National Gas Emergency Service on 0800 111 999.
- ▶ L.P.G. boilers: Call the supplier's number on the side of the gas tank.

Contents

1	KEY TO SYMBOLS AND SAFETY INSTRUCTIONS	3
1.1	Key to symbols	3
1.2	Safety precautions	3
2	APPLIANCE INFORMATION	5
2.1	Appliance	5
2.2	Layout	6
2.3	Technical data	8
2.4	Energy efficiency	9
3	PRE-INSTALLATION	11
3.1	Cleaning primary systems	11
3.2	Mains supply	11
3.2.1	Electrical supply	11
3.2.2	Gas supply	11
3.2.3	Water supply	11
3.3	Water systems and pipe work	12
3.4	Condensate pipe work	13
3.4.1	Internal connections	13
3.4.2	External connections	14
3.5	Pressure relief pipe work	15
3.6	Boiler location and clearances	16
3.6.1	Installation	16
3.6.2	Installation and servicing clearances	16
3.6.3	Compartments	16
3.6.4	Bathrooms	16
3.7	Plumbing manifold	17
3.7.1	Connections	17
3.8	Flue options	18
3.8.1	Flue lengths	18
3.9	Flue terminal positions	20
3.10	Plume management terminal positions	21
3.10.1	Determine the plume management system length	22
4	INSTALLATION	23
4.1	Unpacking wall frame & ancillary items	23
4.2	Wall mounting template & flue opening	23
4.3	Unpacking the appliance	24
4.4	Pre-plumbing boiler connections	25
4.5	Hanging the boiler	27
4.6	Flue turret/adaptor installation	28
4.7	Electrical	29
4.7.1	Mounting optional plug-in controls	30
4.7.2	New complete system installations	31
4.7.3	Existing installations	31
5	COMMISSIONING	33
5.1	Pre-Commissioning checks	33
5.2	Filling the system	33
5.3	Water treatment	33
5.4	Starting the appliance	34
5.4.1	Boiler start up screens	35
5.5	Commissioning	36
5.5.1	Checking the gas inlet pressure	36
5.5.2	Checking the gas rate	37
5.5.3	Gas rating test	37
5.5.4	Checking for leaks during operation	37
5.6	Domestic hot water	37
5.6.1	Domestic hot water eco and preheat modes	37
5.7	CO and combustion checks	38
5.8	Finishing commissioning	39
5.8.1	Replacing the boiler case:	39
5.8.2	Securing the control panel	39

5.8.3	Fitting the fascia flap	39
5.8.4	Installing bottom panel	39
5.8.5	Hand over	40
5.8.6	Boiler guarantee	40
6	SERVICE AND SPARES	41
6.1	Inspection and service	41
6.2	Checking flue integrity	41
6.3	Component access	42
6.4	Checking the gas inlet pressure	42
6.5	Fan pressure test	42
6.5.1	Setting the boiler to maximum	42
6.5.2	Fan pressure	43
6.6	Flue gas analysis	43
6.7	Cleaning the heat exchanger	44
6.7.1	Cleaning the siphon	44
6.7.2	Cleaning the primary heat exchanger	45
6.8	Replacement of parts	46
6.8.1	Removing the outer case	46
6.8.2	Draining the boiler	46
6.8.3	Syphon removal	47
6.8.4	Primary sensor (CH NTC)	47
6.8.5	Maximum safety sensor (NTC)	47
6.8.6	Flue overheat thermostat	47
6.8.7	Air Pressure Switch	48
6.8.8	Auto air vent	48
6.8.9	Gas valve	48
6.8.10	Fan assembly	49
6.8.11	Air/gas flap valve assembly	50
6.8.12	Ignition transformer	51
6.8.13	Electrode assembly	51
6.8.14	Burner housing, burner/ gasket	51
6.8.15	Heat exchanger	52
6.8.16	Diverter valve motor and diverter valve removal	52
6.8.17	DHW Temperature sensor (NTC)	53
6.8.18	Pump head	53
6.8.19	Flow sensor, flow restrictor and filter removal	53
6.8.20	Flow regulator	53
6.8.21	Pressure gauge	54
6.8.22	Boiler return sensor (NTC)	54
6.8.23	Drain tap	54
6.8.24	CH pressure relief valve	54
6.8.25	DHW pressure relief valve	55
6.8.26	DHW plate heat exchanger	55
6.8.27	Hydraulic block removal	55
6.8.28	Bypass valve	55
6.8.29	Access to boiler control components	56
6.8.30	Replacing the control unit	56
6.8.31	Expansion vessel	57
6.9	Short parts list	59
7	FAULT FINDING AND DIAGNOSIS	60
7.1	Internal wiring diagram	60
7.2	Central heating function	61
7.3	Preheat and DHW function	62
7.4	Protection function	63
7.5	Information and service menus	64
7.5.1	Selecting the information menu	65
7.5.2	Selecting service menus	66
7.5.3	Menu 1 - System parameters	66
7.5.4	Menu 2 - Boiler parameters	66
7.5.5	Reset to factory settings	68
7.5.6	Menu 3 - Boiler maximum & minimum limits	68
7.5.7	Using the test menu	68
7.6	Fault codes	71

1 Key to symbols and safety instructions

1.1 Key to symbols

Warnings

	Warnings in this document are identified by a warning triangle printed against a grey background. Keywords at the start of a warning indicate the type and seriousness of the ensuing risk if measures to prevent the risk are not taken.
--	---

The following keywords are defined and can be used in this document:

- **NOTICE** indicates a situation that could result in damage to property or equipment.
- **CAUTION** indicates a situation that could result in minor to medium injury.
- **WARNING** indicates a situation that could result in severe injury or death.
- **DANGER** indicates a situation that will result in severe injury or death.

Important information

	This symbol indicates important information where there is no risk to people or property.
--	---

Additional symbols

Symbol	Meaning
1.	a numbered step in an action sequence
▶	a step in an action sequence
→	a reference to a related part in the document or to other related documents
①	a reference number to identify or refer to a part or item
.	a list entry
-	a list entry (second level)

Table 1 Symbols

Examples of additional symbols used

A numbered step in an action sequence

A sequence of numbered steps or actions carried out in a specific order to complete a task.

1. First action
2. Second action
3. Third action
- etc.

A step in an action sequence

A sequence of defined actions or steps carried out in order to complete a task.

- ▶ Action
- ▶ Next action
- ▶ etc

A reference to a related part in the document or to other related documents.

To refer the reader to a specific figure/table/section within the manual.

→ e.g. figure 1.

A reference number to identify or refer to a part or item.

In a related figure, items or parts identified by a sequential number.

List entries, first and second levels

- A single component/item
- A component/list, made up of multiple parts/items.
 - Sub component or sublist of main component/list.
 - etc.

SYMBOLS USED IN THIS MANUAL

	Domestic Hot Water
	Central Heating
	Hot Water Storage Cylinder
	Domestic Cold Water Supply
	Electrical Supply
	Gas Supply

Table 2 Commonly used symbols

PLEASE READ THESE INSTRUCTIONS CAREFULLY BEFORE STARTING INSTALLATION.

These instructions are applicable to the Worcester appliance model(s) stated on the front cover of this manual only and must not be used with any other make or model of appliance.

These instructions apply in the UK and Ireland only and must be followed except for any statutory obligations.

This appliance must be installed and serviced by a **GAS SAFE** registered, competent person. Failure to install correctly could lead to prosecution.

If you are in any doubt, contact the Worcester Technical helpline (0330 123 3366).

Please leave these instructions with the completed BENCHMARK CHECKLIST, (or a certificate confirming compliance with IS 813, Eire only) and the user manual with the owner or at the gas meter after installation or servicing.

Distance learning and training courses are available from Worcester.

The BENCHMARK CHECKLIST can be found in the back of this Installation manual.

∅	Diameter
NG	Natural Gas
LPG	Liquid Petroleum Gas
CH	Central Heating
DHW	Domestic Hot Water
DCW	Domestic Cold Water
DWTA	Domestic Water Treatment Association
PRV	Pressure Relief Valve
NTC	Negative Temperature Coefficient (sensor)
IP	Ingress Protection
RCD	Residual Current Device
TRV	Thermostatic Radiator Valve
ECV	Emergency Control Valve
WRAS	Water Regulations Advisory Scheme
SEDBUK	Seasonal Efficiency of Domestic Boilers in the United Kingdom

Table 3 Abbreviations use in this manual

1.2 Safety precautions

If you smell gas

A gas leak could potentially cause an explosion. If you smell gas, observe the following rules.

- ▶ Prevent flames or sparks:
 - Do not smoke, use a lighter or strike matches.
 - Do not operate any electrical switches or unplug any equipment.
 - Do not use the telephone or ring doorbells.
- ▶ Turn off the gas at the meter or regulator.
- ▶ Open windows and doors.
- ▶ Warn your neighbours and leave the building.
- ▶ Prevent anyone from entering the building.
- ▶ Well away from the building: call the National Gas Emergency Service on 0800 111 999.
- ▶ L.P.G. boilers: Call the supplier's number on the side of the gas tank.

Appliance operation:

This appliance can be used by children aged from 8 years and above and persons with reduced physical, sensory or mental capabilities or lack of experience and knowledge, if they have been given supervision or instruction concerning the use of the appliance, in a safe way, and understand the hazards involved.

Children shall not play with the appliance.

Cleaning and user maintenance shall not be made by children without supervision.



Benchmark places responsibilities on both manufacturers and installers.

The purpose is to ensure

that customers are provided with the correct equipment for their needs, that it is installed, commissioned and serviced in accordance with the manufacturer's instructions by competent persons and that it meets the requirements of the appropriate Building Regulations. The Benchmark Checklist can be used to demonstrate compliance with Building Regulations and should be provided to the customer for future reference.

Installers are required to carry out installation, commissioning and servicing work in accordance with the Benchmark Code of Practice which is available from the Heating and Hotwater Industry Council who manage and promote the scheme.

Visit centralheating.co.uk for more information.

Health and safety

The appliance contains no asbestos and no substances have been used in the construction process that contravene the COSHH Regulations (Control of Substances Hazardous to Health Regulations 1988).

Combustion and corrosive materials

Do not store or use any combustible materials (paper, thinners, paints etc.) inside or within the vicinity of the appliance.

Chemically aggressive substances can corrode the appliance and invalidate any warranty.

Fittings and modifications

Fitting the appliance and any controls to the appliance may only be carried out by a competent engineer in accordance with the current Gas Safety (Installation and Use) Regulations.

Flue systems must not be modified in any way other than as described in the fitting instructions. Any misuse or unauthorised modifications to the appliance, flue or associated components and systems could invalidate the warranty. The manufacturer accepts no liability arising from any such actions, excluding statutory rights.

Servicing

Advise the user to have the system serviced annually by a competent, qualified Gas Safe registered engineer. Approved spares must be used to help maintain the economy, safety and reliability of the appliance.

Important

The service engineer must complete the Service Record on the Benchmark Checklist after each service.

Flue System



Only use the approved Worcester Condensifit II flue system with this appliance.

Worcester original spare parts

Only use Worcester original spare parts with this appliance. Non Worcester original spare parts will invalidate the guarantee (if applicable) and any warranty.

2 Regulations

Installation regulations

Current Gas Safety (Installation & Use) Regulations:

All gas appliances must be installed by a competent person in accordance with the above regulations.

Failure to install appliances correctly could lead to prosecution.

The appliance must be installed in accordance with, and comply to, the current: Gas Safety Regulations, IET Regulations, Building Regulations, Building Standards (Scotland) (Consolidation), Building Regulations (Northern Ireland), local water by-laws, Health & Safety Document 635 (The Electricity at Work Regulations 1989), EU Regulations No. 811/2013 - Energy Labelling and any other local requirements.

British standards

Where no specific instruction is given, reference should be made to the relevant British Standard codes of Practice.

BS7074:1 Code of practice for domestic and hot water supply

BS6891 Installation of low pressure gas pipe work up to 28mm (R1)

BS5546 Installation of gas hot water supplies for domestic purposes

EN12828 Central heating for domestic premises

BS5440:1 Flues and ventilation for gas appliances of rated heating not exceeding 70kW (net): Flues

BS5440:2 Flues and ventilation for gas appliances of rated heating not exceeding 70kW (net): Air Supply

BS7593 Treatment of water in domestic hot water central heating systems

BS6798 Installation of gas fired boilers of rated input up to 70kW (net)

L.P.G. Installations

An appliance using L.P.G. must not be installed in a room or internal space below ground level unless one side of the building is open to the ground.

Irish Standards

The relevant Irish standards should be followed, including:

- ECTI National rules for electrical installations
- IS 813:2002 for Domestic Gas Installations.

Timber Framed Buildings

Where the boiler is to be fitted to a timber framed building the guidelines laid down in BS5440: Part 1 and IGE "Gas Installations in Timber Frame Buildings" should be adhered to.

Potable Water

All seals, joints and compounds (including flux and solder) and components used as part of the secondary domestic water system must be approved by WRAS.

CH Water

Artificially softened water must not be used to fill the central heating system.

3 APPLIANCE INFORMATION

3.1 Appliance

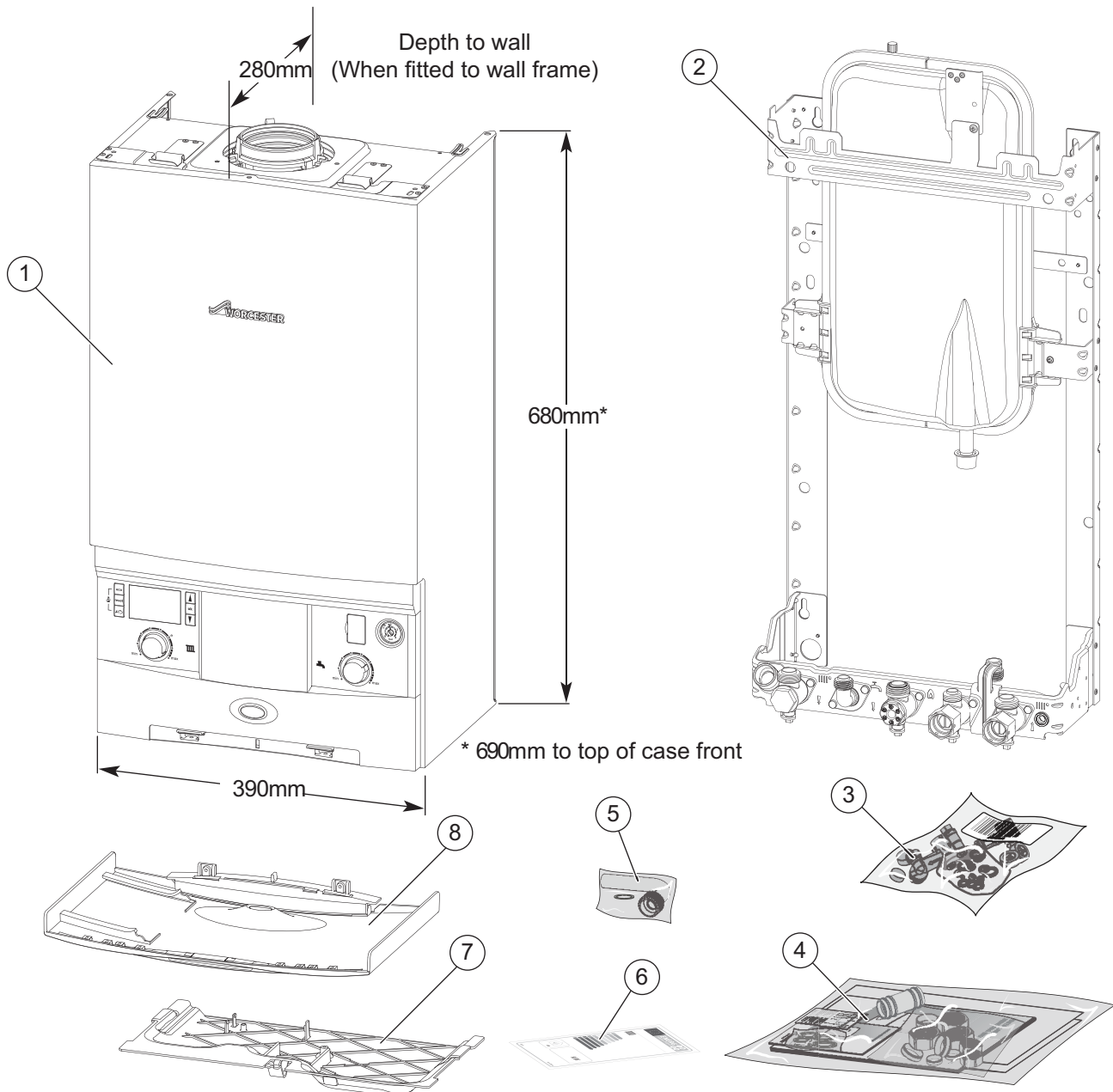

6720813276-01.1W0

STANDARD PACKAGE

1. Wall hung gas-fired condensing combi boiler for central heating and domestic hot water
2. Wall mounting frame
3. Integral Filling Loop kit
4. Hardware literature pack:
 - Greenstar CDi Compact ^{ErP} Installation, Commissioning and Servicing Instructions
 - User guide
 - Boiler fascia guide
 - Wall mounting template
 - Sealing Pack
5. PRV installer connection elbow
6. ErP label
7. Fascia panel
8. Bottom panel

3.2 Layout

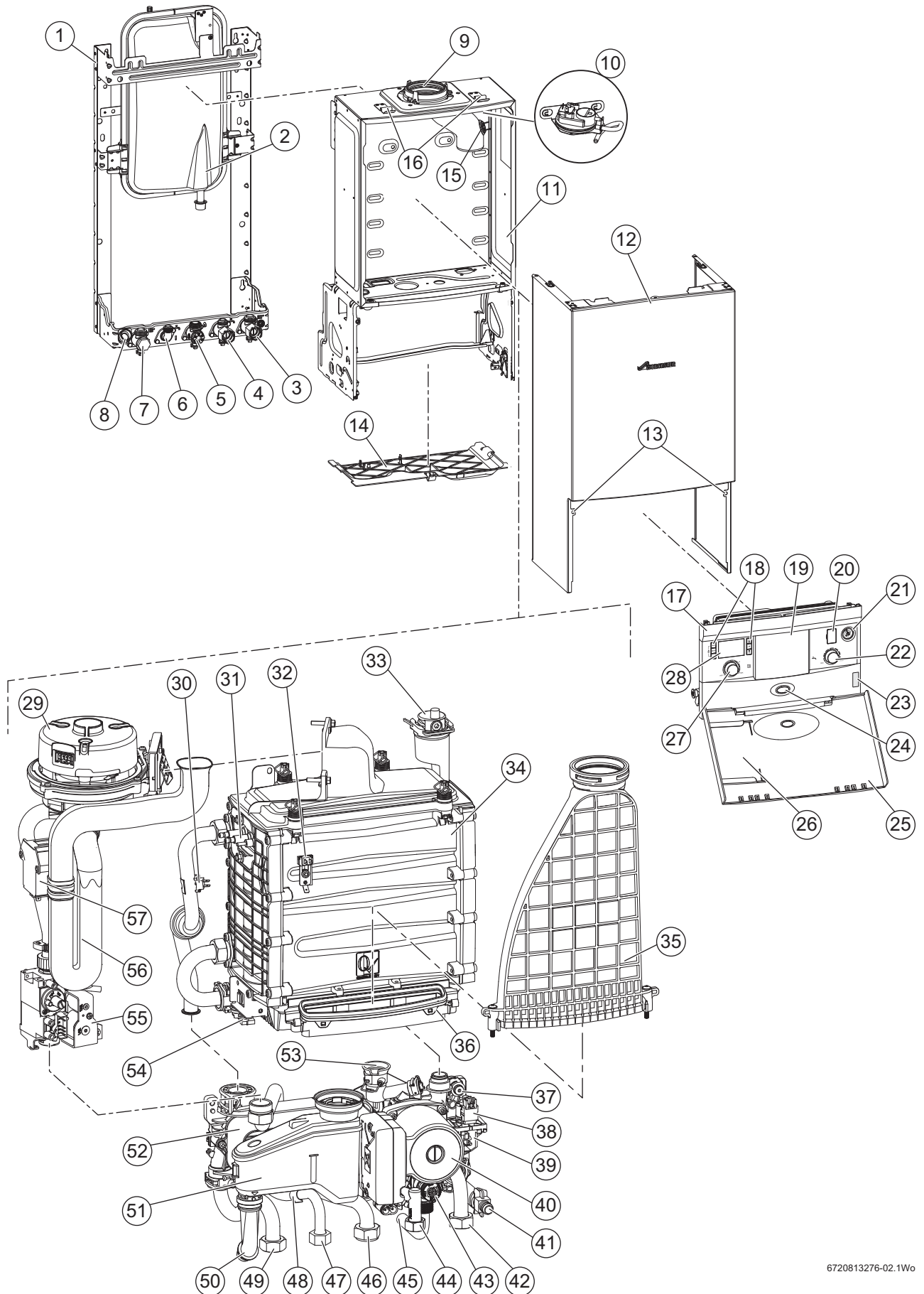

6720813276-02.1Wo

Fig. 1 Main boiler components

1	Wall mounting frame	30	Flow temperature sensor (NTC)
2	Expansion vessel	31	Electrode assembly
3	CH return isolating valve	32	Maximum safety sensor (NTC)
4	DCW mains isolating valve	33	Auto air vent
5	Gas isolating valve	34	Aluminium Silicon Heat exchanger
6	DHW outlet connection	35	Flueway
7	CH flow isolating valve	36	Sump assembly
8	Condensate drain connection	37	Pressure gauge connection point
9	Flue connector	38	Diverter valve actuator (stepper motor)
10	Air Pressure Switch	39	Diverter valve body
11	Main superstructure	40	Modulating pump
12	Case	41	Drain point
13	Case retaining screws	42	CH return connection to isolating valve
14	Bottom panel	43	PRV
15	Flue Overheat Thermostat	44	DCW in connection to isolating valve
16	Case retaining clips	45	PRV Connection pipe
17	Control panel	46	Gas pipe from isolating valve
18	Control panel menu buttons	47	DHW outlet pipe
19	Blank for optional programmer	48	DHW temperature sensor (NTC)
20	Diagnostic port - Worcester service engineer	49	CH flow pipe to isolating valve
21	Pressure gauge	50	Condensate siphon drain pipe
22	DHW temperature control	51	Condensate siphon
23	Boiler identification label	52	DHW Plate heat exchanger
24	Operation/fault indicator (blue)	53	Expansion vessel connection
25	Control panel flap	54	Return temperature (NTC)
26	Boiler fascia guide location	55	Gas valve
27	CH temperature control	56	Combustion air inlet
28	Boiler display	57	Ignition transformer
29	Fan		

Table 4 Boiler components

BOILER FEATURES

- High pressure die-cast aluminium heat exchanger
- Low NOx emissions
- Fixed gas valve settings
- Direct burner ignition
- Zero pressure governor gas valve with fully modulating fan
- Display for boiler status and access to diagnostics, system and commissioning parameters
- Digital control system
- Memory retention after power interruption
- Low electrical power consumption during operation and stand-by modes
- Modulating pump
- Condensing in CH and DHW modes
- Three star Hot Water Comfort measured to EN13203 Part 1 in comfort mode with DHW pre-heat ON
- Eco mode, to use gas on demand
- Plate type DHW heat exchanger
- Ability to pre-plumb condensate drain, CH flow, DHW Outlet, Gas, DCW In, PRV and CH Return connections
- Siphonic condensate trap
- Galvanised steel wall mounting frame
- Standard wall frame provides vertical pipe route behind the boiler
- Compatible with all Worcester standard and intelligent controls
- Condensifit II flue systems 60/100 and 80/125mm allows plume re-direction as standard and ability to attach plume management kits

3.3 Technical data

DESCRIPTION CDi Compact ErP	UNIT	Natural gas			L.P.G.		
		28kW	32kW	36kW	28kW	32kW	36kW
Domestic Hot Water							
Minimum heat input	kW	7.15	7.15	7.15	7.15	7.15	7.15
Maximum rated heat output	kW	28	32	36	28	32	36
Maximum rated heat input	kW	28.57	32.65	36.7	28.57	32.65	36.7
Maximum mains inlet pressure (standing pressure)	bar	10	10	10	10	10	10
Minimum mains inlet pressure (working) for max. flow	bar	1.6	1.6	1.6	1.6	1.6	1.6
Minimum mains inlet pressure (working) for operation	bar	0.2	0.2	0.2	0.2	0.2	0.2
Minimum required flow to fire the boiler	l/min.	2	2	2	2	2	2
Domestic Hot Water temperature range	°C	40 - 60	40 - 60	40 - 60	40 - 60	40 - 60	40 - 60
¹⁾ Max. Domestic Hot Water flow rate - 40 °C rise ± 15%	l/min.	10.0	11.0	13.0	10.0	11.0	13.0
Gas flow rate - Max. 10 minutes from lighting							
Natural Gas G20	m ³ /h	3.0	3.5	3.9			
Propane Gas (L.P.G.)	kg/h			-	2.2	2.5	2.8
Central Heating							
Maximum rated heat input (net)	kW	24.34	24.34	24.34	24.34	24.34	24.34
Maximum rated heat output 40/30 °C	kW	25.31	25.31	25.31	25.31	25.31	25.31
Maximum rated heat output 50/30 °C	kW	25.17	25.17	25.17	25.17	25.17	25.17
Maximum rated heat output 80/60 °C	kW	24	24	24	24	24	24
Maximum flow temperature	°C	82	82	82	82	82	82
Maximum flow temperature possible	°C	86	86	86	86	86	86
Maximum permissible operating pressure	bar	2.5	2.5	2.5	2.5	2.5	2.5
Available pump head at 20 °C system temperature rise	m	2.0	2.0	2.0	2.0	2.0	2.0
Flue							
Flue gas temperature 80/60 °C, rated/min. load	°C	67/64	72/64	78/64	69/66	73/66	79/66
Flue gas temperature 40/30 °C, rated/min. load	°C	48/36	51/36	52/36	50/37	52/37	54/37
CO ₂ level at max. rated heat output (after 10 minutes)	%	9.1	9.1	9.1	10.6	10.6	10.6
CO ₂ level at min. rated heat output (after 10 minutes)	%	8.5	8.5	8.5	9.6	9.6	9.6
NOx class		5	5	5	5	5	5
NOx rating	mg/kWh	35	35	35	46	46	46
Condensate							
Maximum condensate rate	l/h	2.5	2.5	2.5	2.5	2.5	2.5
pH value, approx.		4.8	4.8	4.8	4.8	4.8	4.8
Electrical							
Electrical power supply voltage	a.c. V	230	230	230	230	230	230
Frequency	Hz	50	50	50	50	50	50
Maximum power consumption - running	W	105	115	129	105	115	129
Maximum power consumption - stand-by	W	1	1	1	1	1	1
General data							
Appliance protection rating	IP	X4D	X4D	X4D	X4D	X4D	X4D
Appliance protection rating with mechanical or RF mechanical timer or FW100 module fitted	IP	IP20	IP20	IP20	IP20	IP20	IP20
Appliance protection rating with Sense II control fitted	IP	IPX2D	IPX2D	IPX2D	IPX2D	IPX2D	IPX2D
Permissible ambient operating temperatures	°C	0 - 50	0 - 50	0 - 50	0 - 50	0 - 50	0 - 50
Nominal capacity of appliance	litre	2.2	2.2	2.2	2.2	2.2	2.2
Total packaged weight	kg	43.1	43.1	43.1	43.1	43.1	43.1
Total boiler weight		39.5	39.5	39.5	39.5	39.5	39.5
Lift weight	kg	32.9	32.9	32.9	32.9	32.9	32.9
SEDBUK 2009	%	89.8	89.8	89.8	91.9	91.9	91.9

Table 5 Technical data

- 1) Greenstar CDi Compact ErP boilers are fitted with a flow regulator set to achieve a 40°C temperature rise. This ensures comfortable bathing during the colder winter months.

3.4 Energy efficiency

Natural gas appliances

The following product data satisfy the requirements of the EU Regulations No. 811/2013 and No. 812/2013 supplementing Directive 2010/30/EU.

Product data	Symbol	Unit	773360053	773360055	773360056
Product type	–	–	28CDi Compact ^{ErP}	32CDi Compact ^{ErP}	36CDi Compact ^{ErP}
Condensing boiler	–	–	Yes	Yes	Yes
Low temperature boiler	–	–	No	No	No
B1 boiler	–	–	No	No	No
Cogeneration space heater (CHP)	–	–	No	No	No
Combination heater	–	–	Yes	Yes	Yes
Rated heat output	P_{rated}	kW	24	24	24
Seasonal space heating energy efficiency	η_s	%	94	94	94
Energy efficiency class	–	–	A	A	A
Useful heat output					
At rated heat output and high temperature regime ¹⁾	P_4	kW	24	24	24
At 30% of rated heat output and low temperature regime ²⁾	P_1	kW	8.1	8.1	8.1
Useful efficiency					
At rated heat output and high temperature regime ¹⁾	η_4	%	88.8	88.8	88.8
At 30% of rated heat output and low temperature regime ²⁾	η_1	%	99.5	99.5	99.5
Auxiliary electricity consumption					
At full load	$e_{l,max}$	kW	0.029	0.029	0.029
At part load	$e_{l,min}$	kW	0.014	0.014	0.014
In standby mode	P_{SB}	kW	0.001	0.001	0.001
Other items					
Standby heat loss	P_{stby}	kW	0.078	0.078	0.078
Ignition burner power consumption	P_{ign}	kW	0	0	0
Emissions of nitrogen oxides	NOx	mg/kWh	25	25	25
Annual energy consumption	Q_{HE}	kWh	-	-	-
Sound power level, indoors	L_{WA}	dB(A)	52	52	52
Additional data for combination heaters					
Declared load profile	–	–	XL	XL	XL
Daily electricity consumption	Q_{elec}	kWh	0.144	0.137	0.141
Annual electricity consumption	AEC	kWh	32	30	31
Daily fuel consumption	Q_{fuel}	kWh	20.667	20.741	20.702
Annual fuel consumption	AFC	GJ	18	18	18
Water heating energy efficiency	η_{wh}	%	85	85	85
Water heating energy efficiency class	–	–	A	A	A

Table 6 Product data for energy consumption according to the EU regulations no. 811/2013 and no. 813/2013

- 1) High temperature regime means 60 °C return temperature at heater inlet and 80 °C feed temperature at heater outlet.
- 2) Low temperature means for condensing boilers 30 °C, for low-temperature boilers 37 °C and for other heaters 50 °C return temperature (at heater inlet).

LPG appliances

The following product data satisfy the requirements of the EU Regulations No. 811/2013 and No. 812/2013 supplementing Directive 2010/30/EU.

Product data	Symbol	Unit	7733600057	7733600058	7733600059
Product type	–	–	28CDi Compact ^{ErP}	32CDi Compact ^{ErP}	36CDi Compact ^{ErP}
Condensing boiler	–	–	Yes	Yes	Yes
Low temperature boiler	–	–	No	No	No
B1 boiler	–	–	No	No	No
Cogeneration space heater (CHP)	–	–	No	No	No
Combination heater	–	–	Yes	Yes	Yes
Rated heat output	P_{rated}	kW	24	24	24
Seasonal space heating energy efficiency	η_s	%	94	94	94
Energy efficiency class	–	–	A	A	A
Useful heat output					
At rated heat output and high temperature regime ¹⁾	P_4	kW	24	24	24
At 30% of rated heat output and low temperature regime ²⁾	P_1	kW	8.1	8.1	8.1
Useful efficiency					
At rated heat output and high temperature regime 1)	η_4	%	88.8	88.8	88.8
At 30% of rated heat output and low temperature regime 2)	η_1	%	99.5	99.5	99.5
Auxiliary electricity consumption					
At full load	e_{lmax}	kW	0.029	0.029	0.029
At part load	e_{lmin}	kW	0.014	0.014	0.014
In standby mode	P_{SB}	kW	0.001	0.001	0.001
Other items					
Standby heat loss	P_{stby}	kW	0.078	0.078	0.078
Ignition burner power consumption	P_{ign}	kW	0	0	0
Emissions of nitrogen oxides	NOx	mg/kWh	25	25	25
Annual energy consumption	Q_{HE}	kWh			
Sound power level, indoors	L_{WA}	dB(A)	52	52	52
Additional data for combination heaters					
Declared load profile	–	–	XL	XL	XL
Daily electricity consumption	Q_{elec}	kWh	0.144	0.137	0.141
Annual electricity consumption	AEC	kWh	32	30	31
Daily fuel consumption	Q_{fuel}	kWh	20.667	20.741	20.702
Annual fuel consumption	AFC	GJ	18	18	18
Water heating energy efficiency	η_{wh}	%	85	85	85
Water heating energy efficiency class	–	–	A	A	A

Table 7 Product data for energy consumption

1) High temperature regime means 60 °C return temperature at heater inlet and 80 °C feed temperature at heater outlet.

2) Low temperature means for condensing boilers 30 °C, for low-temperature boilers 37 °C and for other heaters 50 °C return temperature (at heater inlet).

4 PRE-INSTALLATION

4.1 Cleaning primary systems

CAUTION:

- ▶ ISOLATE THE MAINS SUPPLIES BEFORE STARTING ANY WORK AND OBSERVE ALL RELEVANT SAFETY PRECAUTIONS.



NOTICE: All the following pre-installation sections must be read and requirements met before starting the boiler or flue installations.

NOTICE:

- ▶ Debris from the system can damage the boiler and reduce efficiency. Failure to comply with the guidelines for the use of water treatment with the appliance will invalidate the appliance guarantee and contravene the Building Regulations.
- ▶ It is recommended that you fit a primary water cleanser to the system. Worcester recommends fitting a filter that will help remove both magnetite and non-magnetic debris.

BEFORE CLEANING THE SYSTEM:

- ▶ Ensure that the system and pipe work is in good working order.
- ▶ **Where possible keep the existing boiler/circulating pump in place when flushing the system.**

FOLLOW THE GUIDANCE OF BS7593:

Treatment of water in domestic hot water central heating and also the flushing guidelines below.



NOTICE: Artificially softened water must not be used to fill the central heating system.

FLUSHING THE SYSTEM

- ▶ Fill the system with cold water and check for leaks.
- ▶ Open all drain cocks and drain the system.
- ▶ Close drain cocks and add a suitable flushing agent **compatible with aluminium** at the correct strength for the system conditions in accordance with the manufacturer's instructions.
The pH value of the system water must be less than 8 or the appliance guarantee will be invalidated.
- ▶ Circulate the flushing agent before the boiler is fired up.
- ▶ Run the boiler/system at normal operating temperature as directed by the manufacturer of the flushing agent.
- ▶ Drain and thoroughly flush the system to remove the flushing agent and debris.
- ▶ It may be necessary to use a power flushing machine to aid the cleansing procedure in some circumstances.
- ▶ Close the drain cocks and refill with fresh water and a suitable inhibitor.
- ▶ Vent any air from the boiler and system.

Inhibitor

Add a suitable inhibitor or combined inhibitor/anti-freeze, if the system is exposed to freezing conditions, to the heating system in accordance with the DWTa code of practice and manufacturer's guidelines.

WARNING: Sealing agents

- ▶ Normally the addition of sealing agents to the system water is not permitted as this can cause problems with deposits left in the heat exchanger.
- ▶ In cases where all attempts to find a micro leak have failed, Worcester, Bosch Group supports the use of Fernox F4 leak sealer.

Water treatment products

Suitable water treatment products can be obtained from the following manufacturers:

FERNOX	0870 601 5000 or www.fernox.com
SENTINEL	0800 389 4670 or www.sentinel-solutions.net

Artificially softened water

It is possible to have an ion exchange water softener fitted to the cold water system of the property. However, the boiler requires an untreated cold water connection taken from the mains supply, before the water softener, to the primary water filling point of the heating system.

4.2 MAINS SUPPLY

4.2.1 Electrical supply

- Supply: 230V - 50 Hz
- Cable: PVC insulated 0.75mm² (24 x 0.2mm) temperature rated to 90 °C.
- External 3A fuse to BS1362.
- The boiler must be earthed.
- This boiler must not be connected to a 3 phase supply.
- IPX4D.

NOTICE: IP rating change

IP rating IPX4D is reduced to IP20 if the following controls are fitted:
MT10, 7 716 192 036 or MT10RF, 7 716 192 037
or FR100 7 716 192 067.
This is reduced to IPX2D when the Sense II 7 738 111 064 is fitted.

- Wiring must comply with the latest edition of BS 7671 (IET wiring regulations).

4.2.2 Gas supply

To ensure that the equipment is in good working order and can meet the gas flow and pressure requirements, in addition to the demand from any other appliance being served, the following applies:

- Boilers using Natural Gas (NG) must be connected to a governed meter.
- Liquid Petroleum Gas (LPG) must be connected to a regulator.
- Installation and connection of the gas supply to the boiler must be in accordance with BS6891.
- Gas pipe sizing should be calculated to ensure no more than the permitted mbar drop between the meter/governor to the appliance inlet. (→ Commissioning section).
- The meter or regulator and pipe work to the meter must be checked, preferably by the gas supplier.

4.2.3 Water supply

Water mains pressure:

- Minimum mains water pressure for maximum performance: refer to the Technical data in section 3.3.
- Maximum mains fed water pressure 10 bar.
If necessary fit a pressure reducing valve.



NOTICE: Non return, back flow prevention devices (including those associated with water meters) fitted to the mains water supply can cause a pressure build up which could damage the boiler and other household appliances.

- Where the mains water supply has a non-return, back flow prevention valve fitted, a mini expansion vessel (1) should be connected to the mains water inlet pipe (2) between the non-return valve (3) and the boiler (4) as shown below.

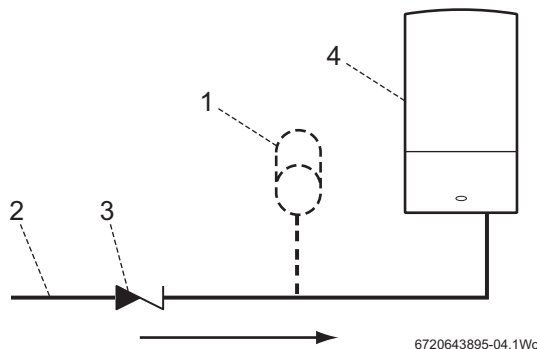

1	Mini expansion vessel - part no. 7 716 192 105
2	Mains water inlet pipe
3	Non return valve
4	Boiler

Use in hard water areas:

Normally there is no need for water treatment to prevent scale formation as the maximum temperature of the DHW heat exchanger is limited by the electronic control.

In areas where temporary water hardness exceeds 200 ppm, consideration may need to be given to the fitting of a scale prevention device. In such circumstances, the advice of the local water authority should be sought.

4.3 Water systems and pipe work

PLASTIC PIPE WORK:

- Any plastic pipe work must have a polymeric barrier with 600mm (minimum) length of copper pipe before being connected to the boiler.
- Plastic pipe work used for underfloor heating must be correctly controlled with a thermostatic blending valve limiting the temperature of the circuits to approximately 50°C.

PRIMARY SYSTEMS CONNECTIONS/VALVES:

- All system connections, taps and mixing valves must be capable of sustaining a pressure up to 3 bar.
- Radiator valves should conform to BS2767:10.
- All other valves should conform to BS1010.
- Thermostatic radiator valves (TRV's) must be fitted to all rooms except bathrooms and the room in which the room thermostat is fitted.
- A drain cock is required at the lowest point(s) in the system.
- An air vent is required at the high point(s) in the system.



The boiler is equipped with an internal by-pass. The internal bypass is not intended to be a substitute for an external system bypass. An external automatic bypass should be used if the system flow can be significantly adjusted or stopped by zone valves and thermostatic radiator valves (TRV).

SHOWERS/BIDETS:

- If a shower head can be immersed in water or comes closer than 25mm from the top edge of a bath or shower tray spill over level then an anti-siphon device must be fitted to the shower hose.
- Bidets with direct hot and cold mains water can be used (with the approval of the local water authority) and must be the over rim flushing type with shrouded outlets to prevent the fitting of hand held sprays.

SEALED PRIMARY SYSTEM:



NOTICE: Artificially softened water must not be used to fill the central heating system.

- The CH sealed system must be filled using a WRAS approved filling loop or comply with figure 2 for system fill.
- Where the system volume is more than 100 litres or exceeds 2.65 bar at maximum heating temperature, an extra expansion vessel (2) must be fitted as close as possible to the appliance in the central heating return.
- Pressurise the extra expansion vessel (2) to the same figure as the expansion vessel built into the appliance, (approximately 0.75 bar).
- **Do not use galvanised pipes or radiators.**

SYSTEM FILL

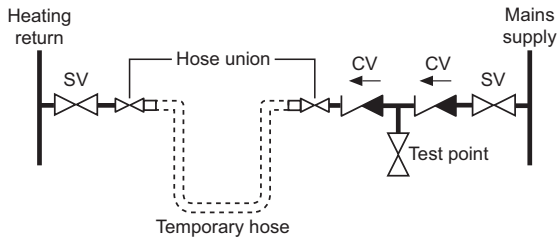

CV = Check Valve
SV = Stop Valve

Fig. 2 System fill

TYPICAL SEALED SYSTEM

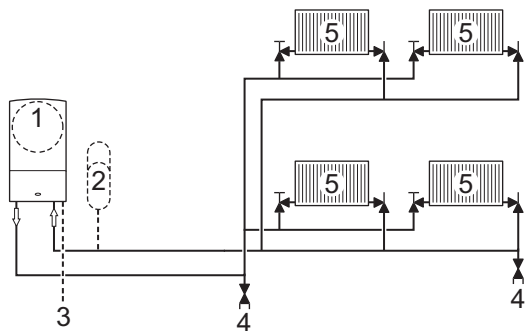

6720643895-06.1Wo

Fig. 3 Sealed system

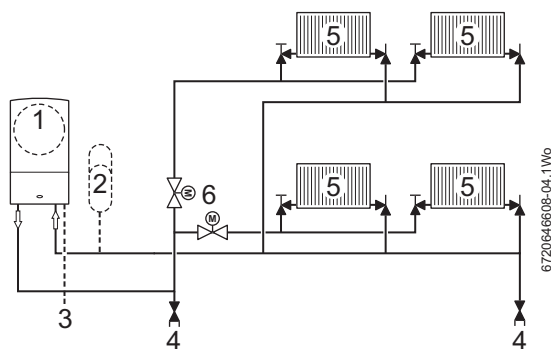

672046608-04.1Wo

Fig. 4 Sealed system with zone valves

1	Appliance expansion vessel - CH
2	Extra expansion vessel - CH return
3	Pressure relief discharge
4	Drain cock
5	Radiators
6	Zone valves

Table 8 Key to figs. 3 and 4

Available pump head



In order to save as much energy as possible and the minimise the possibility of water circulation noise, a low characteristic should be chosen.

The pump map can be selected within 2.1C in the Boiler settings menu list:

- **0** (pump variable speed setting)
- **1** (constant pressure low)
- **2** (constant pressure low/middle)
- **3** (constant pressure middle/high)
- **4** (constant pressure high)

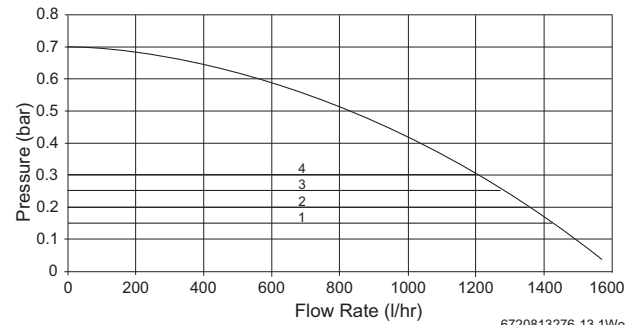

6720813276-13.1Wo

The factory setting is:

4 (constant pressure high)

Constant pressure head

If the constant pressure head option (1 - 4) is chosen, the differential pressure between the CH flow and return will be kept at the corresponding value. When the CH system is cold and the radiator TRVs are fully open, the pump will be running faster to try and maintain the pressure differential. When the TRVs start to close and the resistance of the CH system increases, the pump speed reduces to maintain the pressure.

The setting (1 - 4) to be selected is dependent upon the resistance and heat load of the CH system. The higher these are, the higher the pressure constant

4.4 Condensate pipe work



NOTICE:

- ▶ Where a new or replacement boiler is being installed, access to an internal "gravity discharge" point should be one of the factors considered in determining boiler location.
- ▶ The condensate pipe must be nominally 22mm Ø plastic pipe.
- ▶ The condensate pipe work must fall at least 52mm per metre towards the outlet and should take the shortest practicable route.
- ▶ Ensure there are no blockages in the pipe run.

Key to condensate illustrations

1	Condensate discharge from boiler
2	Soil and vent stack
3	Minimum 450mm and up to three storeys
4	Visible air break at plug hole
5	Sink or basin with integrated overflow
6	75mm sink waste trap
7	Condensate pump
*	Condensate trap of 75mm already incorporated into the boiler

4.4.1 Internal connections

In order to minimise risk of freezing during prolonged cold spells, the following methods of installing condensate drainage pipe should be adopted, in order of priority.

Wherever possible, the condensate drainage pipe should be routed and terminated so that the condensate drains away from the boiler under gravity to a suitable internal foul water discharge point such as an internal soil and vent stack. A suitable permanent connection to the foul waste pipe should be used.

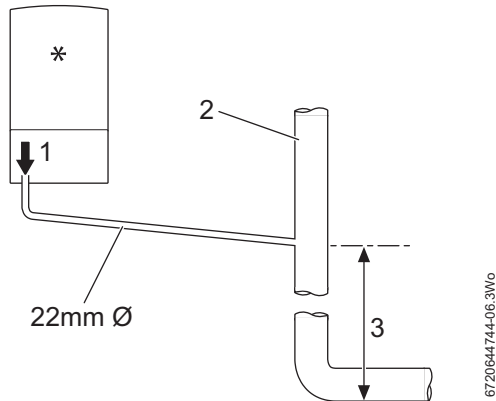

Fig. 5 Disposal to soil vent stack

Alternatively if the first option is not possible an internal kitchen or bathroom waste pipe, washing machine waste pipe etc. can be used. Ensure that the condensate drain pipe is connected “down stream” of the waste trap.

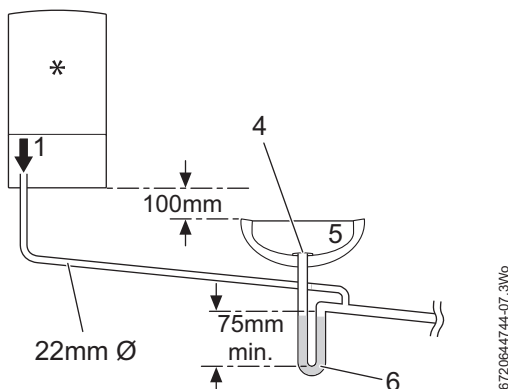

Fig. 6 Disposal to a waste pipe

CONDENSATE PUMP

Where “gravity discharge” to an internal termination is not physically possible, or where very long internal runs would be required to reach a suitable discharge point, condensate should be removed using a proprietary condensate pump, of a specification recommended by the boiler or condensate pump manufacturer.

The pump outlet pipe should discharge to a suitable internal foul water discharge point such as an internal soil and vent stack, internal kitchen or bathroom waste pipe, washing machine waste pipe etc. A suitable permanent connection to the foul waste pipe should be used.

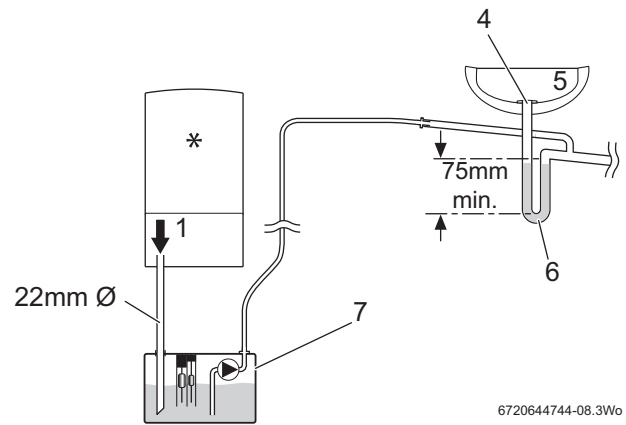

Fig. 7 Condensate pump disposal

4.4.2 External connections

NOTICE: Freezing conditions

- ▶ When the position of the boiler prevents internal routing, we recommend installing a CondenseSure siphon to significantly reduce the risk of freezing.
- ▶ Pipe work length should be kept to a minimum and the route as vertical as possible.
- ▶ Weather proof insulation must be used, if not using a CondenseSure siphon.

NOTICE: Condensate waste

- ▶ Care should be taken when siting a soak-away to avoid obstructing existing services.

Continued - Key to condensate illustrations	
8	PVCu strap on fitting
9	100mm Ø minimum plastic pipe
10	Drainage holes
11	Limestone chippings
12	Bottom of sealed tube
13	Insulate and increase pipe size
14	Pipe work transition
15	External air break
16	Air gap
17	External rain water pipe into foul water
18	43mm 90° male/female bend
*	Condensate trap of 75mm already incorporated into the boiler

If no other discharge method is possible then the use of an externally run condensate drainage pipe terminating at a suitable foul water discharge point, or purpose-designed soak away, may be considered. If this method is chosen then the following measures should be adopted:

- ▶ Use a CondenseSure siphon to help prevent the condensate freezing.
- ▶ The external run be kept as short as possible and not exceed 3 metres.
- ▶ The pipe should be run internally as far as possible before going externally and the pipe diameter should be increased to 32mm before it passes through the wall to the exterior. The pipe should be insulated using suitable waterproof and weather resistant insulation, if not using a CondenseSure siphon.
- ▶ The external pipe should take the shortest and least exposed route to the discharge point, and should “fall” as steeply as possible away from the boiler, with no horizontal runs in which condensate might stand.

- ▶ The use of fittings, elbows etc. should be kept to a minimum and any internal “burrs” on cut pipe work should be removed so that the internal pipe section is as smooth as possible.

FITTING AN EXTERNAL AIR BREAK

- Refer to figure 8 when a rain water down pipe is used to dispose of condensate.
- An air break must be installed in the 43mm pipe work, between the boiler condensate outlet and the drainpipe, outside the property, to avoid flooding during adverse weather conditions.

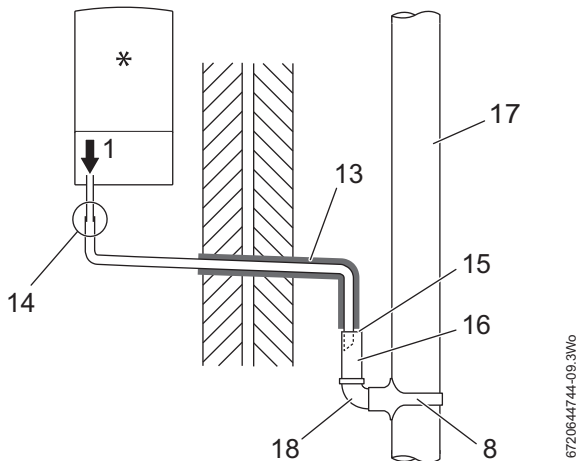

Fig. 8 Disposal into a rainwater down pipe



Condensate drainage pipe can be run above or below ground.

Where the pipe terminates over an open drain or gully, the pipe should terminate below the grating level, but above water level, in order to minimise “wind chill” at the open end.

The use of a drain cover (such as those used to prevent blockage by leaves) may offer further protection from wind chill.

Pipe drainage will be improved if the end is cut at 45° as opposed to a straight cut.

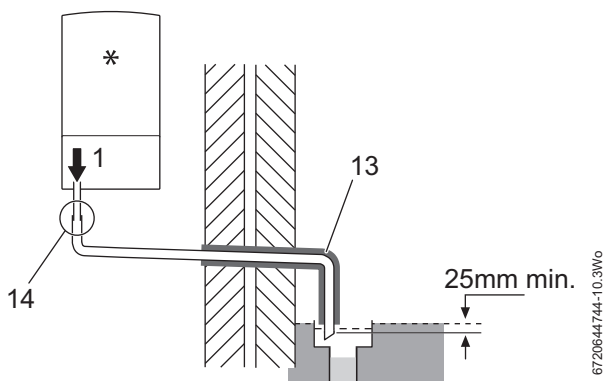

Fig. 9 External disposal

CONDENSATE SOAK AWAY

- The condensate drainage pipe may be run above or below the ground to the soak away. The examples shown on this page run above ground.
- The soak away must use a 100mm Ø plastic tube with two rows of three 12mm holes on 25mm centres and 50mm from the bottom of the tube. The holes must face away from the house.
- The tube must be surrounded by at least 100mm of limestone chippings to a depth of 400mm.



Minimum hole size for the condensate soak away must be 400mm deep by 300mmØ .

In situations where there are likely to be extremes of temperature or exposure, the use of a proprietary trace-heating system for external pipe work, incorporating an external frost thermostat, should be considered. If such a system is used, the requirement to use 32mm pipe does not apply. However, all other guidance above and the instructions for the trace heating system, should be closely followed.



NOTICE: Unheated internal areas.

- ▶ Internal pipe runs in unheated areas such as lofts, basements and garages should be treated as external runs and consideration should be given to using a CondenseSure siphon.

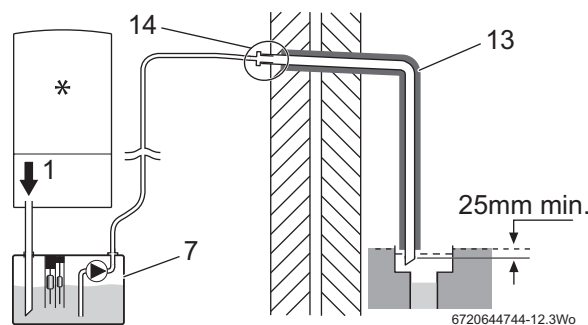

Fig. 10 Condensate pump to external disposal

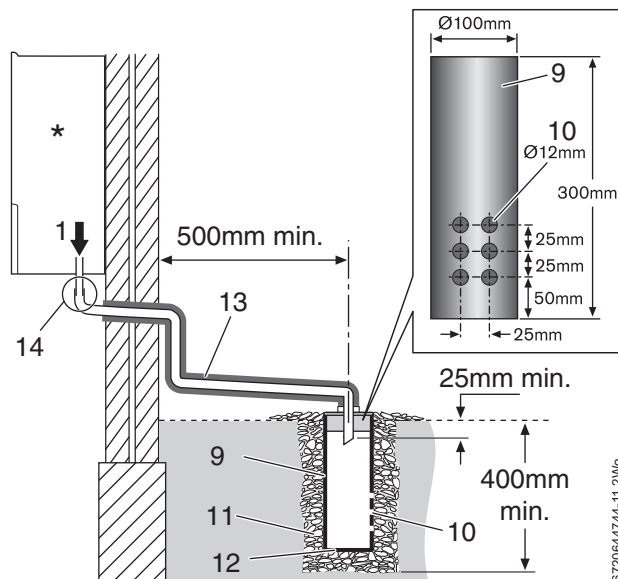

Fig. 11 Soak away

4.5 Pressure relief pipe work



NOTICE:

- ▶ The pressure relief valve is a safety device for the boiler and if activated may discharge boiling water or steam through the relief valve drain pipe.
- ▶ Care should be taken when siting the outlet pipe so that it does not cause an obstruction or discharge above a window, entrance or other public access where it could cause a hazard.

- The pressure relief drain pipe (1) from the boiler should be at least 15mm diameter copper pipe and run downwards, away from any electrical equipment or other hazard, preferably to an external drain or soak away.
- The pressure relief drain pipe (1) should be finished with a partial bend, near the outlet to face the external wall (as shown) to help prevent freezing.

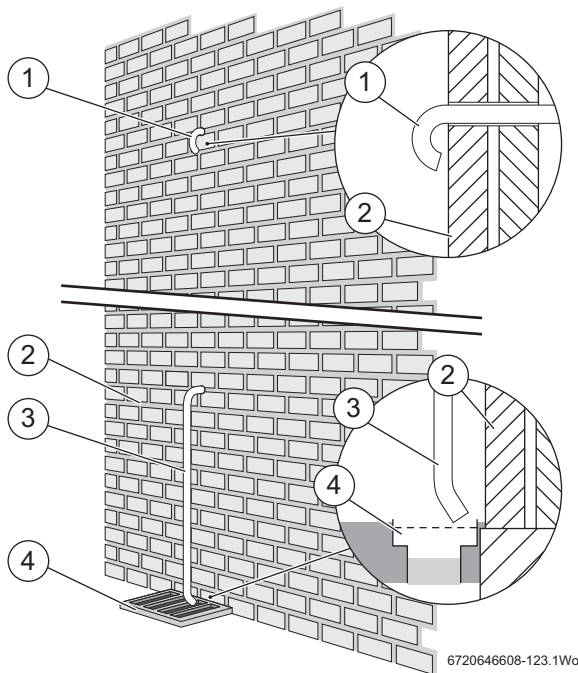

Fig. 12 Pressure relief pipe work

- [2] Outside wall
- [1, 3] PRV drain pipe
- [4] External drain

4.6 Boiler location and clearances

4.6.1 Installation

This appliance is only suitable for installing internally within a property at a suitable location onto a fixed, rigid surface at least the same size as the appliance and capable of supporting the appliance weight.



No surface protection is required against heat transfer from the appliance.

The appliance must be installed where:

- An engineer can gain clear and safe access to work on the product or component, including making adequate provision for visual inspection of flues in voids.
- The homeowner can gain clear and safe access to the controls, check, top up or reset the appliance.
- Products in loft cavities must have permanent fixed lighting, a permanent fixed retractable ladder and a fixed floor area sufficient to allow access for normal use and servicing directly under and around the product and between and the access hatch.

4.6.2 Installation and servicing clearances

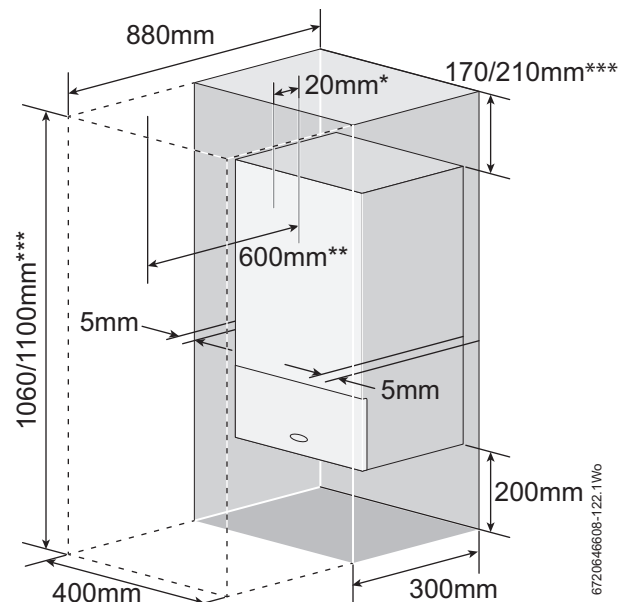

Fig. 13 Unventilated compartment

- [*] Minimum clearance to removable door
- [**] Minimum clearance required for servicing
- [***] Height for either 60/100 flue or 80/125 flue

4.6.3 Compartments

Follow the requirements of BS6798 and BS5440 Part 2 and note:

- Minimum clearances must be maintained.
- An access door is required to install, service and maintain the boiler and any ancillary equipment.
- If fitting the boiler into an airing cupboard use a non-combustible material to separate the boiler from the airing space. The material can be perforated up to a maximum hole size of 13mm.

4.6.4 Bathrooms

Please check the IP rating of any control to be used on this appliance. Only certain controls can be fitted when the appliance is inside of the shaded area.

An appliance with blanking panel or controls that do not change the IP rating can be installed in zone 2.

Additional RCD (Residual Current Device) protection may be required. Consult the latest version of BS7671 (IET wiring regulations).

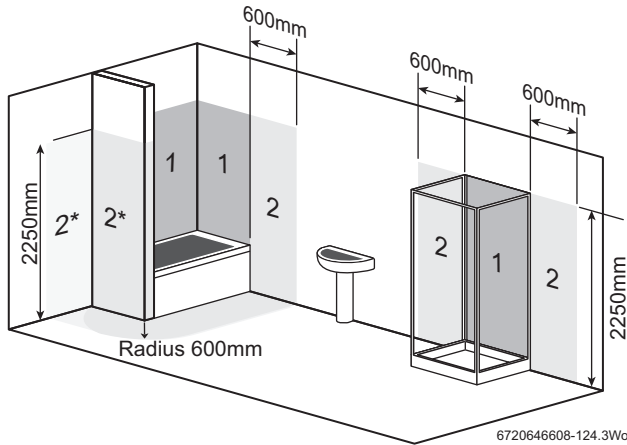

Fig. 14 Bathroom installations

[2*] Without the end wall, zone 2 must extend 600mm from the bath

4.7 Plumbing manifold

4.7.1 Connections

Heating System	22mm compression fittings
DHW	15mm compression fittings
Gas	22mm compression fittings

Use the fittings supplied in the Hardware literature pack.

i Further guidance on pipe routing can be found printed on the boiler template (supplied with the boiler).

- For further ease of fitting, an optional Vertical Pre-piping Assembly kit is available, comprising four pre-formed copper water pipes. Part number: 7 716 192 713.

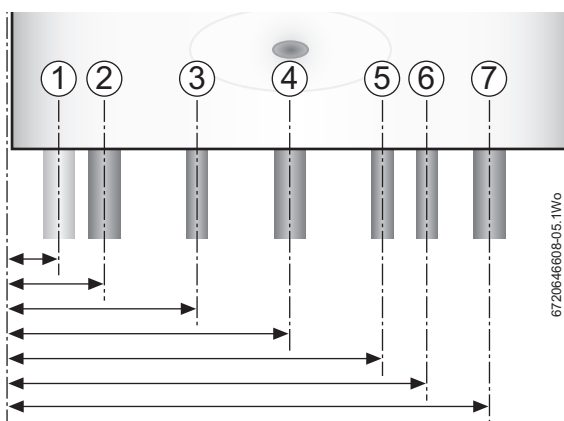

Fig. 15 Pipe dimensions

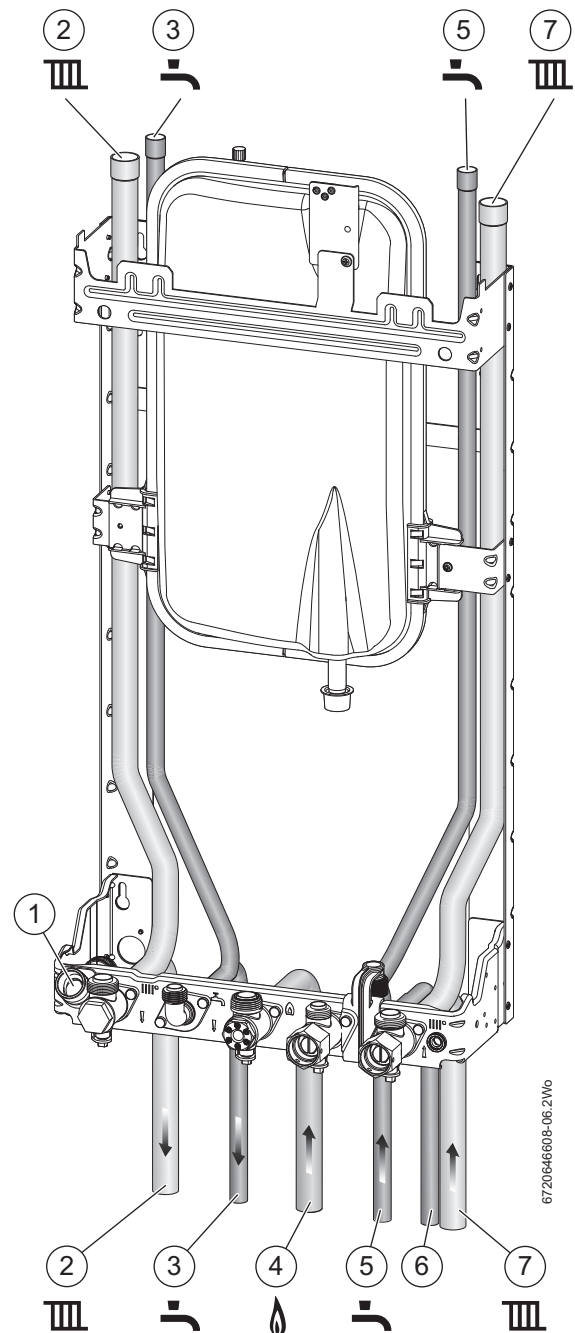

Fig. 16 Plumbing manifold

No.	Function	From left case edge	Diameter of pipe
1	Condensate drain	33mm	22mm
2	CH Flow	65mm	22mm
3	DHW Outlet	130mm	15mm
4	Gas	195mm	22mm
5	DCW Mains In	260mm	15mm
6	PRV drain	291mm	15mm
7	CH Return	325mm	22mm

Table 9 Key to figures 15 & 16

4.8 Flue options

WARNING: Flue systems

- ▶ Only use Worcester, Bosch approved flue systems, no other manufacturer's flue systems have been approved for use with Worcester appliances.

CAUTION: Non accessible flue systems:

- ▶ Where a flue system is not going to be accessible, provision must be made for service and inspection.
- ▶ Voids containing concealed flues must have at least one inspection hatch no less than 300mm square.
- ▶ Flue joints within the void must not be more than 1.5 metres from the edge of the inspection hatch.
- ▶ Inspection hatches should be located at changes of direction.
- ▶ If this is not possible, bends should be viewable from both directions.

NOTICE: Effective flue lengths:

- ▶ each 90° bend is equivalent to 2 metres of straight flue
- ▶ each 45° bend is equivalent to 1 metre of straight flue

i Plume management kits are available for the 60/100 horizontal flue system, Part number 7 716 191 086. Refer to the manual supplied with the Plume Management kits for complete installation instructions

Part number	Flue	Description
7 716 191 082	60/100	Telescopic horizontal flue assembly
7 716 191 171	60/100	Longer telescopic horizontal flue assembly
7 733 600 048	60/100	Horizontal high level telescopic flue kit
7 719 003 702	80/125	Telescopic horizontal flue assembly
7 719 002 430	60/100	Vertical flue assembly
7 719 002 431	80/125	Vertical flue assembly

Table 10 Flue kit part numbers

4.8.1 Flue lengths

The flue systems have different maximum flue lengths

The Greenstar series has the option of two horizontal 60/100 RSF (telescopic and longer telescopic) and one horizontal 80/125 RSF (telescopic) flue system and two vertical RSF (60/100 or 80/125) flue systems:

Refer to the following example Flue options for the maximum flue lengths.



Horizontal high level flue assembly

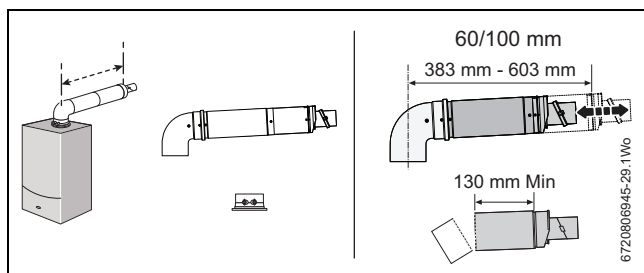

	Flue length (mm)	
	60/100	80/125
Horizontal high level telescopic flue assembly	202 - 603	N/A

Table 11

Telescopic horizontal flue assembly

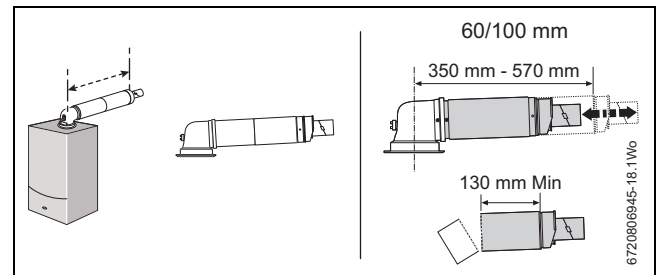

	Flue length (mm)	
	60/100	80/125
Telescopic horizontal flue assembly	180 - 570	405 - 600
Longer telescopic horizontal flue assembly	570 - 790	N/A

Table 12

Extended horizontal flue

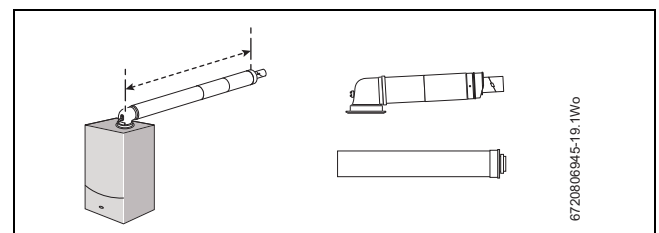

	Maximum flue length (mm)	
	60/100	80/125
Extended horizontal flue	6,000	15,000

Table 13

Horizontal flue with additional elbow (1 x 90° bend)

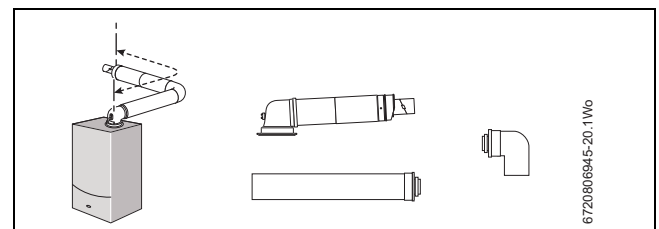

	Maximum flue length (mm)	
	60/100	80/125
Horizontal flue with 1 x 90° bend	4,000	13,000

Table 14

Horizontal flue with additional elbows (2 x 90° bends)

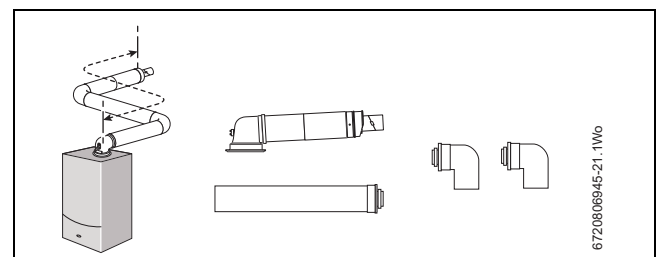

	Maximum flue length (mm)	
	60/100	80/125
Horizontal flue with 2 x 90° bends	2,000	11,000

Table 15