

Switchsocket Outlets

Standards and approvals

Logic Plus 13A socket outlets comply with BS 1363: Part 2: 1995.

Replacement fuses to the 3 gang socket outlets comply with BS 1362: 1973.

Technical specification

Electrical

Voltage rating:
250V a.c.

Current rating:
13A per socket outlet
(except 3 gang which is 13 amp in total)

Terminal capacity:
Live, neutral & earth
3 x 2.5mm²
3 x 4mm²
2 x 6mm² (standard)
(Dual earth terminals on list Nos.
K781 WHI, K2657 WHI, K2737 WHI, K2746 WHI, K2757 WHI)

Physical

Ambient operating temperature:
-5°C to +40°C
(not to exceed an average of more than 25°C in any 24 hour period)

IP rating:
IP2XD

Max. installation altitude:
2000 metres

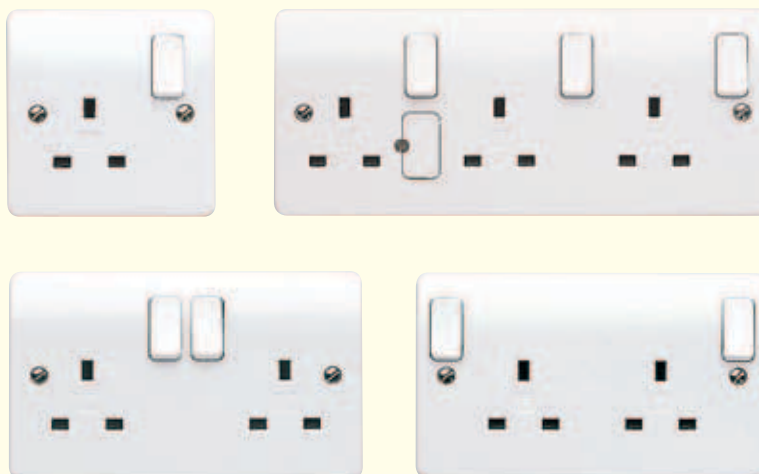

Description

A range of socket outlets designed for ease of installation and having all the advantageous design features of the Logic Plus range. The 2 gang sockets with outboard rockers are of particular value for use by the infirm and partially sighted.

Non-standard clean earth sockets are for use on installations where restricted access is required and will only accept MK LN647 13A non-standard plug with T-shaped earth pin. The sockets have two independent earth terminals so that they can also be used for 'clean earth' installations. K2746 CE WHI has two independent earth terminals for 'clean earth' installations.

K781 WHI, K2657 WHI, K2737 WHI, K2746 WHI and K2757 WHI are fitted with two earth terminals on a common busbar to provide a double earth facility for use when installations require a high integrity protective connection as specified within BS 7671: 2008.

The products can be quickly installed as replacement for existing 13 amp sockets or in a new installation.

Fuse carriers (3 gang switchsocket only)

The fuse carrier is opened by a fast-acting, screwdriver-operated, worm-drive screw for ease of replacement.

Round pin sockets

A range of round pin sockets is also available, switched and unswitched.

BOX TYPES				
	Flush	Flush (for extra wiring space)	Surface Insulated	Surface Metal
1 gang	861 ZIC	866 ZIC	K2140 WHI	K2211 ALM/K2213 ALM
2 gang	862 ZIC	886 ZIC	K2142 WHI	K2212 ALM/K2214 ALM
3 gang	K863 ZIC	Not available	K2153 WHI	Not available

Switchsocket Outlets

Features

- Moulded 'on' indicator flash on switches will not rub off – totally safe
 - Optional neon indicators in the switch rockers with 175° visibility in the horizontal and vertical planes
 - 3 pin operated safety shutter
 - Printed terminal markings on grey rear mouldings for clearer identification
 - Top access, angled terminals make wiring easier and quicker
 - 3mm minimum switch contact gap
 - Double pole switching
 - Choice of inboard or outboard positioned rockers
 - Additional electrical safety from neutral
- 'make first', 'break last' feature
 - Switch contacts with silver contacts on both surfaces for good continuity
 - Only one size of screwdriver required for installation
 - Dual earth terminals for high integrity earthing on list Nos. K781 WHI, K2657 WHI, K2737 WHI, K2746 WHI, K2757 WHI
 - Backed out and captive terminal screws
 - 'Clean earth' sockets available
 - Non-standard 'clean earth' sockets available
 - Selected sockets available in graphite finish to assist with Part M compliance

Installation

Logic Plus socket outlets can be wall or bench mounted. Do not mount or use as a trailing socket or where they may be subject to excessive moisture or dampness.

2 gang switchsocket – view from rear

Top-facing, angled, backed-out terminals make wiring easier and quicker.



Dimensions (mm)

1 gang

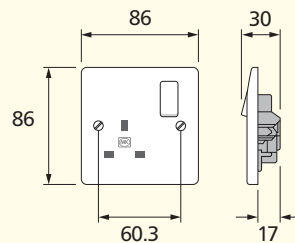

2 gang

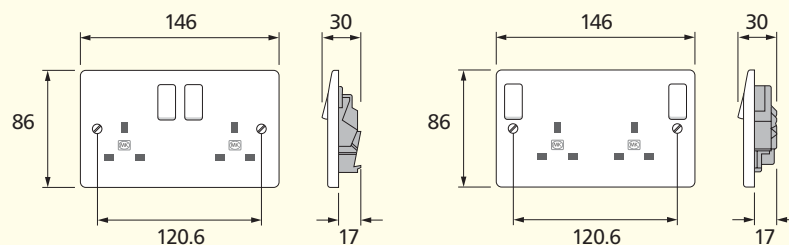

3 gang

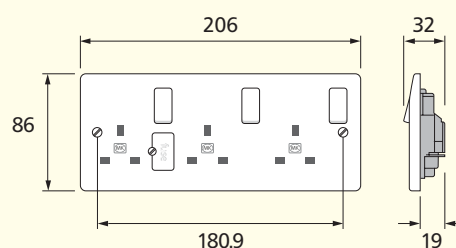

Cable management

Logic Plus socket outlets can be mounted in a variety of MK trunking systems.

Sentrysocket RCD Protected Switchsocket Outlet

Compliance with EC Directives, Standards and approvals

Sentrysockets comply with the following EC Directives and are CE marked:

Low Voltage Directive
Electromagnetic Compatibility Directive (89/336/EEC)

Sentrysocket RCD Single Sockets also comply with the requirements of the following standards:

BS 7288: 1990

BS EN 50082

Sentrysocket RCD Double Sockets comply with BS EN 61543: 1996

Technical specification

Electrical

Rated Voltage:
240V a.c., 50 or 60Hz

Current rating:
13A resistive

Rated tripping current
30mA and 10mA versions

Terminal capacity:
3 x 4mm²

Physical

Ambient operating temperature:
-5°C to +40°C

IP rating:
IP2XD

Max. installation altitude:
2000 metres

Sentrysockets are only suitable for use in TN-S system where the Supply Neutral Connection is connected to the Supply Earth.

They are not suitable for connection across two lines of a 127V line to Neutral Voltage System.



Description

Sentrysocket provides a high level of protection against electrocution and gives further protection when used with appliances vulnerable to insulation damage, particularly when they are in damp environments or outdoors. Sentrysocket is not suitable for mounting in damp environments or outdoors.

Sentrysocket, incorporating an RCD, is part of a complete range of fixed and portable wiring devices and circuit protection devices suitable for use in domestic, commercial and industrial applications.

Active control circuits

Incorporate a 'Re-set' mechanism and are mains failure sensitive, ie they will function under all the normal conditions expected of an RCD, but will also trip in the event of a power cut or a sudden, dramatic reduction in mains voltage. This makes them ideal for use where it would be hazardous for equipment to suddenly energise after return of mains power, such as use with rotating machinery and heat developing apparatus.

Passive control circuits

Incorporate a 'Stay-set' mechanism and is mains failure proof, ie it will function under all the normal conditions expected of an RCD and will not trip in the event of a power cut. This makes it suitable for use with freezers or in inaccessible or unmanned locations.

Features

- Suitable for most residential, commercial and light industrial applications
- Active and passive control circuit applications
- Comply fully with current Wiring Regulations
- Double pole switching
- Flexible and versatile in use
- Ideal for use with equipment subject to wet weather or high humidity
- Part of a complete range of MK circuit protection devices
- They are pulsating DC sensitive for residual current

Installation

Logic Plus RCD protected switch socket outlets can be wall or bench mounted. Do not mount or use as a trailing socket or where they may be subject to excessive moisture or dampness.

Flush mounting steel wall box

It should be noted that some of the conduit entries may be restricted, depending upon their positions and the depth of box used.

Cable management

Sentrysockets can be mounted in a variety of MK trunking systems.

Dimensions (mm)

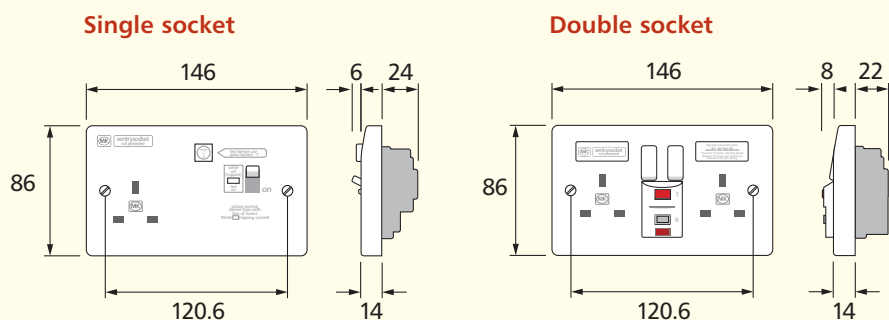

Filtered Switchsocket Outlets

Standards and approvals

Logic Plus Filtered Switch Socket Outlets comply with BS 5733: 1995.

Technical specification

Electrical

Current rating:
13A maximum total for 2 sockets

Voltage rating:
250V a.c. 50Hz

Earth leakage:
0.5 mA

Suppression:
150 kHz – 30 MHz (transients)

Maximum energy absorption:
140 Joules L – N
140 Joules L – E

Terminal capacity:
K1826 and K1816, 2 x 6mm²
3 x 4mm², 3 x 2.5mm², 3 x 1.5mm²

Physical

Operating temperature:
–5°C to +40°C (not to exceed an average of more than 25°C in any 24 hour period)

Thermal overload:
The K1826 filter socket incorporates a thermal overload device in the RFI filter section. Overload current causes temperature rise, resulting in automatic 'trip out'. The overload device will re-set as the temperature falls.

IP rating:
IP2XD

Max. installation altitude:
2000 metres



Description

A range of sockets in the Logic Plus style, designed to combat interference to or data losses on sensitive electrical products and systems due to mains borne voltage spikes and RFI.

Such systems include:

- Computer or microprocessor based equipment
- Telecommunications systems
- Electronic measurement equipment
- Cash registers
- Audio visual and hi-fi equipment

These products can be quickly installed as replacements for existing twin 13 amp sockets or in a new installation.

Two earth terminals on each product provide a double earth facility for use when installations require a high integrity protective connection as specified within BS 7671: 2008.

Filter cassettes

Filter cassettes are supplied with sockets and have an LED which shows green under normal conditions but will turn red or extinguish when a replacement cassette (K1800) is required. An alarm will also beep at 5 second intervals to indicate replacement necessity. It can be de-activated if required.

Cable management

Logic Plus socket outlets can be mounted in a variety of MK trunking systems.

Dimensions (mm)

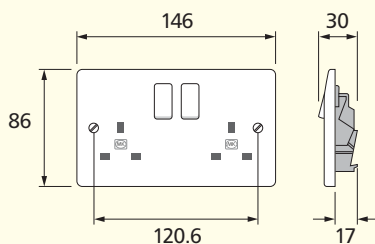

Features

- Moulded 'on' indicator flash on switches will not rub off – totally safe
- 3 pin operated safety shutter
- Printed terminal markings on grey rear mouldings for clearer identification
- Reduces risk of damage to equipment and down time
- Reduces risk of data loss
- 2 way filtering – into appliance and back into mains supply
- Double pole switches
- Dual earth terminals for high integrity earthing
- Clearly visible LED on filter cassette, changes from green to red when replacement required
- Simple replacement of cassettes
- 10 year guarantee (except filter cassette)
- 3mm minimum switch contact gap
- Backed out and captive terminal screws

Round Pin Socket Outlets

Standards and approvals

Round pin socket outlets comply with BS 546: 1950.

Technical specification

Electrical

Voltage rating:
250V a.c.

Terminal capacities:

2 amp sockets (K770):

7 x 1mm²

4 x 1.5mm²

2 x 2.5mm²

1 x 4mm²

5 amp sockets (K771, K2891):

3 x 2.5mm²

2 x 4mm²

2 x 6mm² (stranded)

15 amp sockets (K772, K2893, K2493):

3 x 2.5mm²

3 x 4mm²

2 x 6mm² (stranded)

Physical

Ambient operating temperature:
-5°C to +40°C
(not to exceed an average of more than 25°C in any 24 hour period)

IP rating:
IP2XD

Max. installation altitude:
2000 metres



Description

A range of round pin socket outlets designed for ease of installation and having all the advantages and design features of the round pin Logic Plus range. These products can be quickly installed as replacements for existing socket outlets or in new installations.

Features

- Top access terminals make wiring easier and quicker
- Integral ON indicator on switches will not rub off – totally safe
- Optional neon indicator on 15A switched socket rockers with 175° visibility in the horizontal and vertical planes
- 3mm minimum switch contact gap
- Double pole switching
- Terminal screws backed out
- Additional electrical safety from neutral “make first”, “break last” feature on switched sockets
- Switch contacts with silver contact points on both surfaces for good continuity
- 5A and 15A sockets contain a 3 pin operated safety shutter
- Printed terminal markings on grey rear mouldings for clearer identification
- 2A socket shuttered

Installation

Logic Plus socket outlets can be wall or bench mounted – do not mount or use as a trailing socket or where they may be subjected to excessive moisture or dampness.

Cable management

Logic Plus socket outlets can be mounted in a variety of MK trunking systems.

Dimensions (mm)

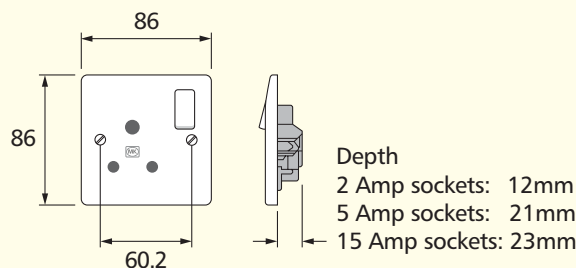

BOX TYPES

	Flush	Flush for extra wiring space	Surface Insulated	Surface Metal
5A and 15A	861 ZIC	866 ZIC	K2140 WHI	K2211 ALM K2213 ALM
2A	3995 ZIC	861 ZIC 866 ZIC	K2140 WHI	K2211 ALM K2213 ALM

NON UK Socket Outlets

Standards and approvals

15A American sockets comply with SASO 2203: 2003

16A Universal sockets comply with BS.5733: 1995

16A 2P+E German sockets comply with IEC 60884-1: 2006

Technical specification

Electrical

15A American Socket

Voltage rating:
127V a.c.

Current rating:
15A

Terminal capacity:
Live, neutral & earth
3 x 2.5mm²
2 x 4mm²
1 x 6mm² (stranded)

Max. installation altitude:
2000 metres

16A Universal Socket

Voltage rating
125/250V

Current rating:
16A

Terminal capacity
2 x 6mm² (stranded)
3 x 4mm² 3 x 2.5mm²

16A 2P+E German Socket

Voltage rating:
250V a.c.

Current rating:
16A

Terminal capacity:
Live, neutral & earth
4 x 1.5mm²
2 x 2.5mm²
1 x 4mm²

Physical

Ambient operating temperature:
-5°C to +40°C
(not to exceed an average of more than 25°C in any 24 hour period)

IP rating:
IP2XD

Max. installation altitude:
2000 metres

15A AMERICAN

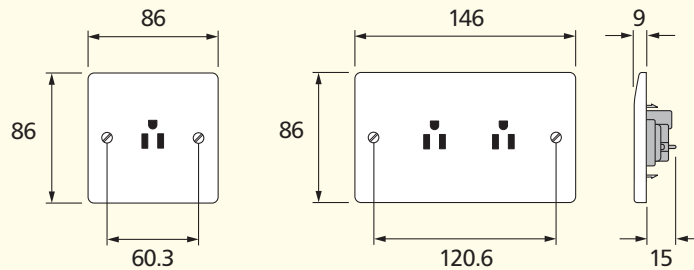

All dimensions in mm

BOX TYPES

	Flush	Flush (for extra wiring space)	Surface
1 gang	861 ZIC	866 ZIC	K2140 WHI
2 gang	862 ZIC	886 ZIC	K2142 WHI

16A UNIVERSAL

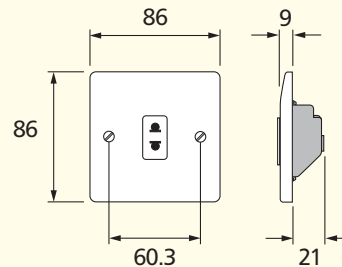

All dimensions in mm

Description

The universal socket does not incorporate an earth contact. Therefore, appliances needing earth connection (class 1 equipment) must NOT be used with this socket. The socket is intended for use with BS, USA and CEE standard plugs.

BOX TYPES

Flush	Surface
861 ZIC	K2140 WHI

16A 2P+E GERMAN

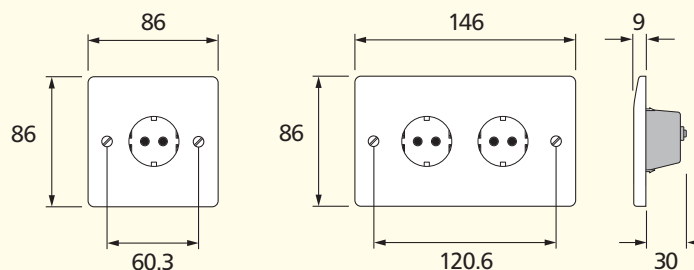

Note:
16A 2P+E German Outlet: These products are NOT suitable for 25mm deep boxes.

All dimensions in mm

Three Pole Fan Isolators

Standards and approvals

Comply with BS EN 60947: 1992

Technical specification

Electrical

Voltage rating:
250V a.c. 50Hz

Current rating:
10 amps

Terminal capacity:
4 x 1mm²
4 x 1.5mm²
3 x 2.5mm²
2 x 4mm²
1 x 6mm²

Contact gap:
3mm switch contact gap

Classifications

Method of operation: Stored energy operation
Suitability for isolation: Suitable for isolation

Ratings

Utilisation category	AC23B
Rated operational voltage (Ue)	250V
Conventional free air thermal current (Ith)	10A
Rated frequency	50Hz
Rated making capacity	100A rms
Rated breaking capacity	80A rms
Rated conditional short-circuit current	6000A rms
(with supply side protective device GEC NIT 16 BS88: part 2: 1988 16A 550VAC utilisation category gG 80KA breaking capacity fuse links.)	

Physical

Operating temperature:
-5°C to +40°C

IP rating:
IP4X

Max. installation altitude:
2000 metres



Description

The MK Three Pole Fan Isolator provides a safe and simple method of isolating mechanical fan units and is particularly useful in bathrooms, toilets, storerooms and basements where there is little or no natural light.

For example, timer controlled fans are often linked into the lighting circuit for energy saving and convenience. In such an installation there is often a need for the lighting circuit to remain live to provide light whilst the fan unit is externally isolated so that routine maintenance and repairs can be carried out in complete safety.

The fan isolator can be used as a double pole or triple pole isolator. In addition it includes a clear on/off indicator and the frontplate features a fan isolator symbol for easy circuit identification.

Dimensions (mm)

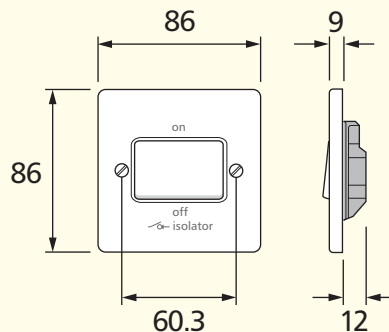

BOX TYPES

Flush	Surface
3995 ZIC	K2160 WHI

Features

- Switchlock list no. K4858 is available to allow the isolator to be locked in the disconnected position to facilitate fan maintenance

Three Pole Fan Isolators

Wiring diagrams

Two pole switching for fan units without timers

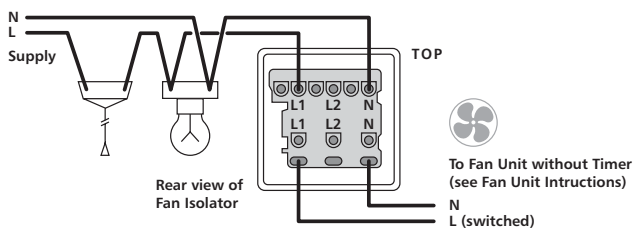
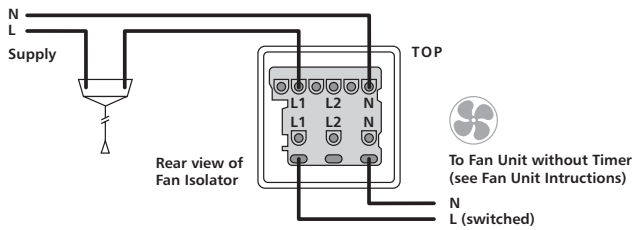

Three pole switching for fan units incorporating timers

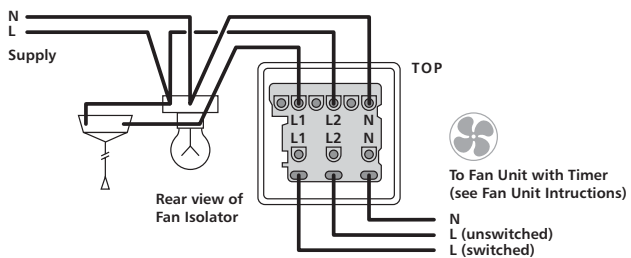
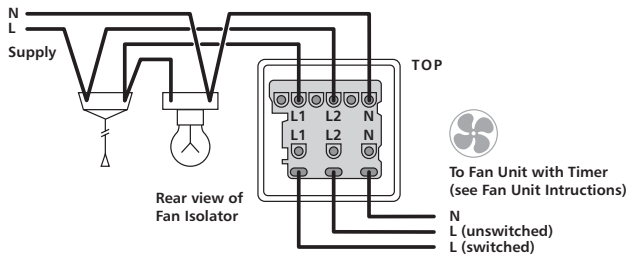

Shaver Socket Outlets

Standards and approvals

Shaver socket outlets comply with BS 4573: 1970 and IEC 884-1: 1994.

Plug pin apertures, and engagement face dimensions comply with BS 4573: 1970.

Technical specification

Electrical

Voltage rating:
200-250V a.c. Input

Maximum load:
200 mA (internal thermister trip current)

Terminal capacities:
Each terminal will accommodate 1 x 4mm²,
or 2 x 2.5mm², 3 x 1.5 solid conductors

Physical

Ambient operating temperature:
-5°C to +40°C

IP rating:
IP2XD

Max. installation altitude:
2000 metres



Description

Designed for ease of installation and having many of the advantageous features of the Logic Plus range.

The shaver socket outlet accommodates the following plugs:

British 5mm dia pins on 16.6mm pitch (230V socket) to BS 4573: 1970.

European 4mm dia pins on 17 to 19mm pitch (230V socket) to IEC 83: 1975 Standard C5.

Australian 6.5 x 1.6 flat blades each set at 30° to the vertical on a nominal pitch of 13.7mm (230V socket) AS C112: 1964.

The fuse carrier is captive and opened by a fast acting, screwdriver operated worm drive screw for ease of replacement.

Installation

Shaver socket outlets may be wall or bench mounted.

This shaver socket **must not** be used in bathrooms and washrooms. Non-isolated, fused, shaver socket outlets must never be installed in any location subject to splashes, condensation or damp conditions.

For installation in any other room where a wash basin or shower cubicle is installed then refer to the current IEE wiring regulations.

Cable management

Logic Plus socket outlets can be mounted in a variety of MK trunking systems.

Features

- Top access terminals make wiring quicker and easier
- Only one size of screwdriver required for installation
- Terminal screws supplied 'backed out' and held captive within the terminal moulding
- Printed terminal markings on grey rear mouldings for clearer identification
- Front plate fixing screws retained on rear case moulding

Dimensions (mm)

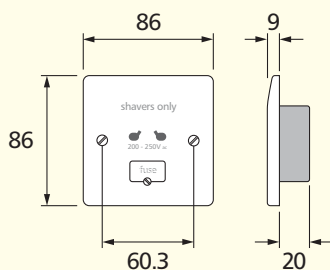

Shaver Supply Units

Standards and approvals

Shaver supply units comply with BS 61558-2-5: 1998

Accommodates plugs as follows:

- British 5mm dia pins on 16.6mm pitch (230V socket) to BS 4573: 1970.
- European 4mm dia pins on 17 to 19mm pitch (230V socket) to IEC 83: 1975 Standard C5.
- Australian 6.5 x 1.6 flat blades each set at 30° to the vertical on a nominal pitch of 13.7mm (230V socket) AS C112: 1964.
- American 6.6 x 1.6 flat horizontal blades on 12.7mm pitch (115V socket) to ANSI C73.10.

Note:

K706 WHI is a Non UK Shaver Supply Unit



Technical specification

Electrical

Voltage rating:

K701: 230V a.c. Input (will operate at 220-250V a.c.)

K706: 127V a.c. Input (will operate at 110-130V a.c.)

230V or 115V nominal outputs

Current rating:

K701: 200mA max. (internal thermister trip current)

K706: 400mA max. (internal thermister trip current)

Maximum load:

20VA

No load voltage < 275V

Terminal capacities:

Each terminal will accommodate 1 x 4mm² or

2 x 2.5mm² solid conductors*

Physical

Ambient operating temperature:

-5°C to +40°C

IP rating:

IP41 (In Zone 2 if fixed where direct spray from showers is unlikely)

Max. installation altitude:

2000 metres

*The design of this unit means that on no load the transformer output is allowed to be as high as 275V. This means that rechargeable shavers intended for use on the continent may be damaged by the inrush current created by this higher voltage. Rechargeable shavers with a wide range of input voltage should be recharged at 115V. Shavers manufactured for the UK are designed to be used with a transformer unit. Loads in excess of 20VA may cause the solid state overload to operate before shaving is completed. This is to protect the transformer.

This product is not suitable for rechargeable toothbrushes.

Description

Designed for ease of installation and having many of the advantageous design features of the Logic Plus range.

May be used in bathrooms and washrooms – must only be installed in accordance with BS 7671: 2008.

Features

- Bottom access terminal screws make wiring quicker and easier
- Automatic primary supply switching on insertion of plug
- Choice of 230V or 115V output socket positions
- Safety interlocked shutters to prevent insertion of two plugs simultaneously
- Only one size of screwdriver required for installation
- Terminal screws supplied 'backed out' and held captive within the terminal moulding
- Printed terminal markings on grey rear mouldings for clearer identification
- Front plate fixing screws retained on rear case moulding
- Integral over current device to protect transformer

Installation

Shaver supply unit should be wall mounted.

Wiring

An installation instruction leaflet is available.

List no. 44994 PL.

Dimensions (mm)

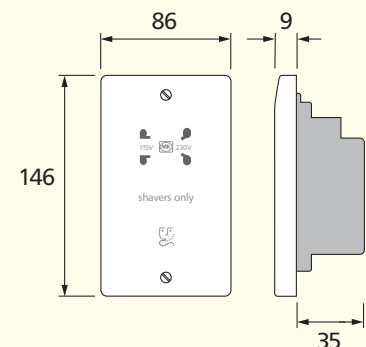

Connection Units, 20A Switches and Flex Outlets

Standards and approvals

All Logic Plus Connection Units comply with BS 1363: Part 4: 1995.

The 20A DP switch complies with BS EN 60669-1: 2000

The flex outlet plate complies with BS 5733: 1995.

Fuses are to BS 1362.

Technical specification

Electrical

Voltage rating:
250V a.c.

Current rating:
Connection units – 13 amp
DP switches – 20 amp
Flex outlets – 20 amp

Terminal capacity:

Supply terminal: 2 x 6mm² stranded
2 x 4mm²
3 x 2.5mm²

Load terminals: 2 x 6mm² stranded
2 x 4mm²
3 x 2.5mm²

Flex outlet/
Cord grip capacity:

Connection units: min: 2 core, 0.5mm
max: 3 core, 1.5mm

20 amp DP
switches & flex outlet plate
min: 3 core, 1.5mm
max: 3 core, 2.5mm

Physical

Ambient operating temperature:
–5°C to +40°C
(not to exceed an average of more than 25°C in any 24
hour period)

IP rating:
With flex outlet: IP2XD
Without flex outlet: IP4X

Max. installation altitude:
2000 metres

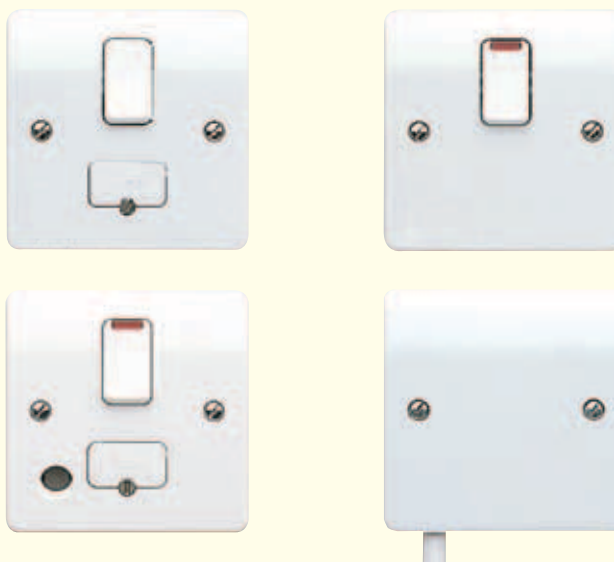

Description

A range of 13A fused Connection Units and 20A DP switches designed for the connection of refrigerators, water heaters, central heating boilers and other fixed appliances.

The ranges are designed for ease of installation and have the advantageous design features of the Logic Plus range.

Neon indicators

Neon indicators can be included in the rockers of the switched connection units. In the case of unswitched units, they are located centrally and uppermost on the front plate. Neon indicators are integrally wired into the product and do not require separate connection when installing.

The design gives 175° visibility in the horizontal and vertical planes.

Fuse carriers

These are captive and are opened by a fast acting, screwdriver operated worm drive for ease of replacement.

A tamper-proof version is also available.

Fuse carriers can be locked open using a padlock, List No. K2000.

Flex outlets

Bottom outlet types are supplied with blanking plug allowing use where the bottom outlet is not required. Spare blanking plugs are available.

The products are equipped with very strong, push-fit nylon cord grips making installation safe, quick and easy.

Flex outlet plate

An unfused flex outlet with cord grip plate and 3 pairs of terminals.

Installation

Logic Plus connection units and 20A cable outlets and 20A switches can be wall or bench mounted. Do not use on a trailing lead.

Wiring

Products must be installed in accordance with current IEE Regulations.

Cable Management

Logic Plus connection units and DP switches can be mounted in a variety of MK trunking systems.

Connection Units, 20A Switches and Flex Outlets

Features

- Optional indicators in the switch rockers with 175° visibility in the horizontal and vertical planes
- Worm-drive operated fuse carriers for additional security (tamper-proof version available)
- Fuse carrier lockable in open position
- All supply and load cables can be cut and stripped to the same length
- Integrally wired indicators save installation time
- Push-fit cord grips, for safer, quicker installation
- Angled, top mounted terminal screws simplify wiring
- Moulded 'on' indicator flash on switches cannot rub off – totally safe
- Captive fuse carrier
- Additional electrical safety from neutral 'make first', 'break last' feature
- Secure cable and flexible cord connection
- All terminal and fixing screws operated by one-size (4mm) screwdriver
- Backed out and captive terminal screws

Note: These switches are not recommended for switching large banks of PCs

Dimensions (mm)

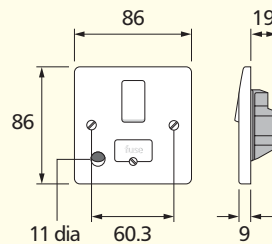

Products with front flex outlet

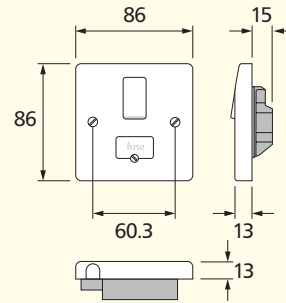

Products with flex outlet in base and thick frontplate

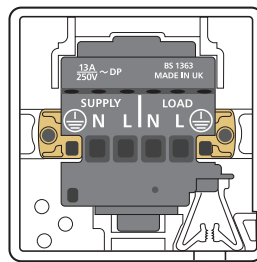

Supply and load cable cords cut and stripped to same length

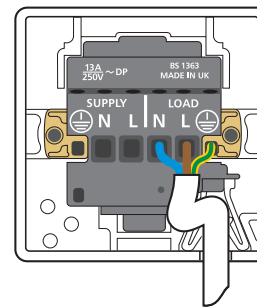

Bottom outlet and cord grip

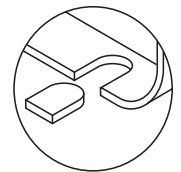

Blanking plug for bottom outlet

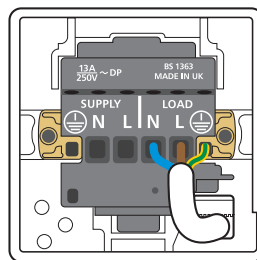

Front outlet cord grip



Lockable fuse carrier

PLEASE NOTE THAT THE TERMINAL LAYOUT OF THE FLEX OUTLET, K1090, IS DIFFERENT TO THAT SHOWN ABOVE. ALL OTHER PRODUCTS ARE AS INDICATED.

High Current Switches and Cooker Control Units

Standards and approvals

All DP switches in the range conform to BS EN 60669-1: 2000

All Cooker Control Units in the range conform to BS 4177: 1992

Cooker Connection Unit conforms to BS 5733: 1995

Technical specification

Electrical

Voltage rating:
250V a.c.

Current:
32A/45A Cooker Control Unit/45A Cooker Connection Unit/50A resistive

Switch:
3mm contact gap
Double pole operation –
except socket switch on Cooker Control Unit

Terminal capacity, 50A switches, Cooker Control Unit and Cooker Connection Unit:

4 x 4mm²
3 x 6mm²
1 x 16mm²

Terminal capacity, 32A Switch:

3 x 2.5mm²
2 x 4mm²
1 x 6mm²

Physical

Ambient operating temperature:
–5°C to +40°C
(not to exceed an average of more than 25°C in any 24 hour period)

IP rating:
IP2XD (K5061, K5060, K5041, K5040, K5001, K5011, K5012)

IP4X (K5105, K5205, K5215CK, K5215SH, K5230)

Max. installation altitude:
2000 metres

Features

- Positive switch action
- Positive double pole switching
- Toggle action switches
- Metal front plates available
- Replaceable neon indicators
- Wide product choice

Note: These switches are not recommended for switching large banks of PCs



Description

A range of switches and cooker control units harmonising with the Logic Plus style, suitable for the switching of all domestic, commercial and industrial appliances where higher current ratings are required, i.e. cookers, heaters etc. Metal units are particularly suitable for refurbishment projects.

BOX DEPTHS

List No.	Max. Cable Size	Flush	Surface
Switches			
K5105 WHI	6mm ² 10mm ²	35mm 46mm	30mm 40mm
K5205 WHI	6mm ² 10mm ²	35mm 46mm	40mm 40mm
K5215 WHI	6mm ² 10mm ²	35mm 47mm	40mm 40mm
K5230 WHI	10mm ²	–	Supplied with box
K5012 WHI	10mm ²	55mm	–

Cooker control units

K5040 WHI	10mm ²	–	Supplied with box
K5041 WHI	10mm ²	–	Supplied with box
K5060 WHI	6mm ² 10mm ²	35mm 47mm	– –
K5061 WHI	6mm ² 10mm ²	35mm 47mm	– –
K5001 WHI	10mm ²	–	Supplied with box
K5011 WHI	10mm ²	55mm	–

BOX REFERENCES

Box depth	Flush		Surface	
	1 gang	2 gang	1 gang	2 gang
30	–	–	K2140 WHI	–
35	886 ZIC	886 ZIC	–	–
40	–	–	K2301 WHI	K2172 WHI
46	877 ZIC	–	–	–
47	–	878 ZIC	–	–
55	5120 ALM (Cooker)	–	–	–

High Current Switches and Cooker Control Units

Dimensions (mm)

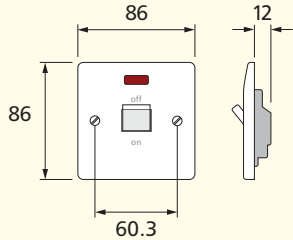
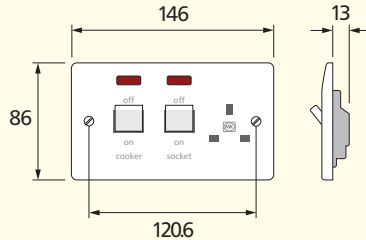
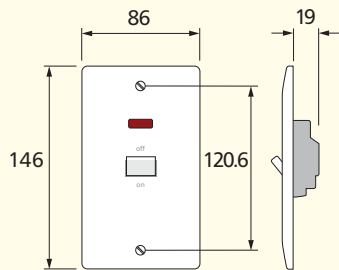
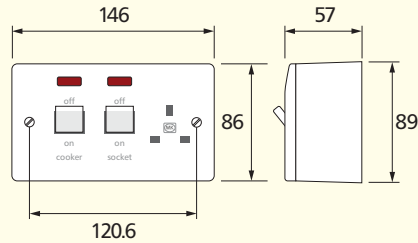
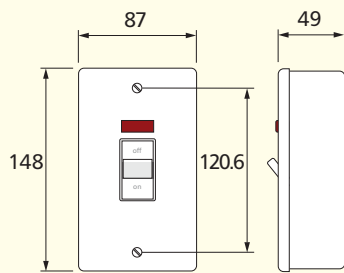
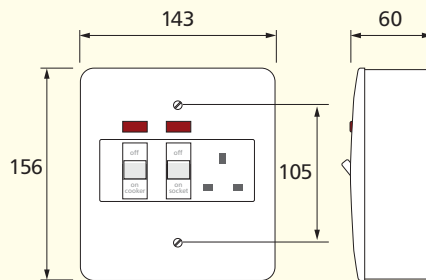
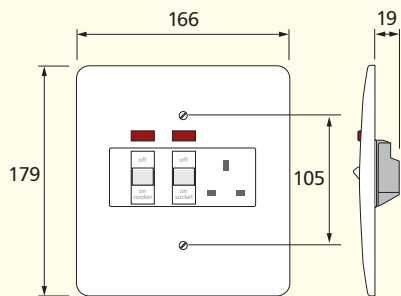
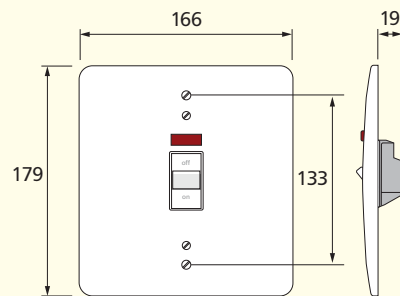
K5105

K5061 or K5060 (without pilot lights)

**K5215 or
K5205 without pilot light
K5215CK printed 'cooker'
K5215SH printed 'shower'**

K5041 or K5040 (without pilot lights)

K5230

K5001

K5011

K5012

Plateswitches

Standards and approvals

All Logic Plus plateswitches comply with BS EN 60669-1: 2000

Technical specification

Electrical

Voltage rating:
250V a.c. 50Hz

Current rating:
10 amps – no derating when used on fluorescent
or inductive loads

20 amps – no derating when used on fluorescent
or inductive loads

Terminal capacity:
All products except K4870/71/72

4 x 1mm²
4 x 1.5mm²
3 x 2.5mm²
2 x 4mm²
1 x 6mm²

For products K4870/71/72

4 x 1mm²
4 x 1.5mm²
2 x 2.5mm²
1 x 4mm²

Contact gap:
3mm switch contact gap

Physical

Operating temperature:
-5°C to +40°C

IP rating:
IP2XD

Max. installation altitude:
2000 metres

Operational testing (all plateswitches):
tested to 100,000 operations for mechanical life
tested to 40,000 operations at 10 amp rating
tested to 10,000 operations at 20 amp rating



Description

Logic Plus plateswitches are designed to blend in with the decor, whilst complementing a wide range of other Logic Plus accessories. They are designed for easy installation in plaster depth boxes and are suitable for controlling lighting circuits in domestic, commercial and industrial applications.

Neon locator

A textured, polycarbonate moulding allowing the glow of the neon to be seen at almost any angle. Designed to complement the Logic Plus 1, 2, or 3 gang plateswitches.

It is easy to install in existing locations. For 3 gang applications using a 25mm deep box simplifies wiring.



Features

- Two way switches can be wired as one or two way
- All products clearly printed with BS Nos., ratings, etc
- Matching Grid switches available in 10 or 20A ratings
- 3mm switch contact gap
- Positive switch action
- Top access, backed out and captive terminal screws
- Neon locator available making switch easy to find in darkened rooms
- Selected plateswitches available in graphite finish to assist with Part M compliance

Cable Management

Logic Plus plateswitches can be mounted in a variety of MK trunking systems.

Plateswitches

Dimensions (mm)

1 gang

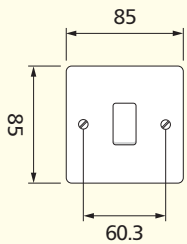

2 gang

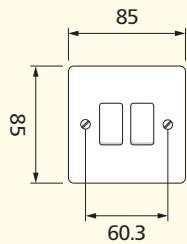

3 gang

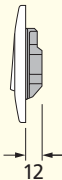
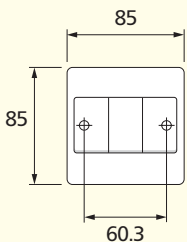
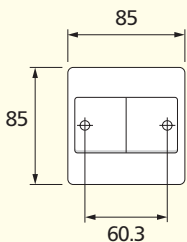
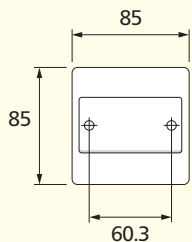
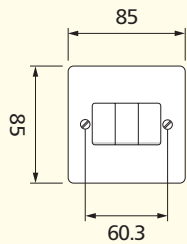

4 gang

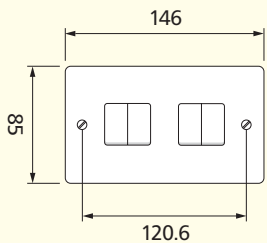

6 gang

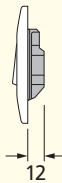
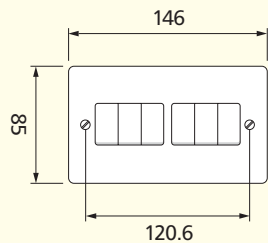

1 gang architrave

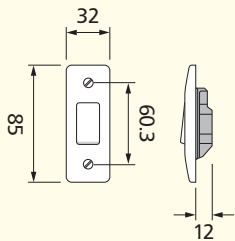

2 gang architrave

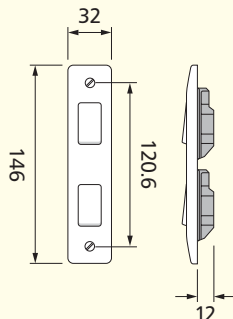

Sectional drawings show the furthest projections from the back of the frontplate (wall surface).

Wiring Diagrams

One-way switching

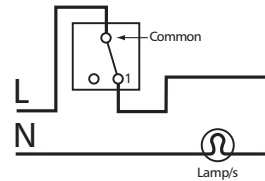

Two-way switching – 2 wire control

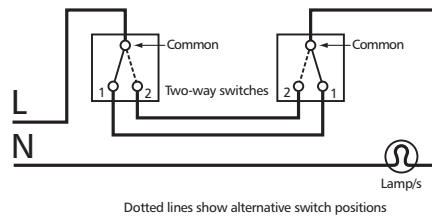

Two-way switching plus intermediate switching – 2 wire control

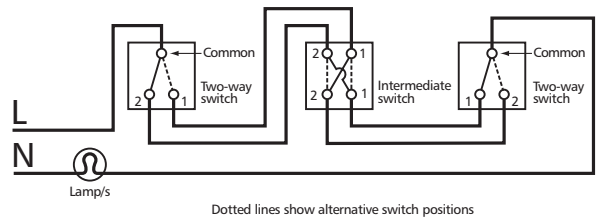

Two-way switching – 3 wire control

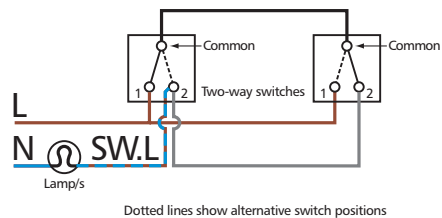

Two-way switching plus intermediate switching – 3 wire control

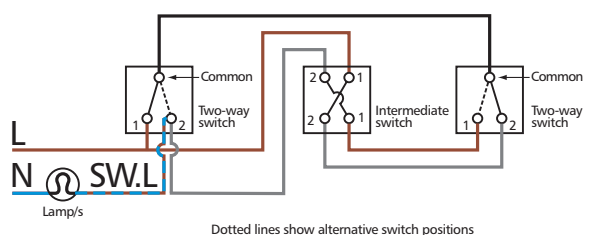

N.B. Terminal positions may alter. The above diagrams are to show wiring layout.

Dimmer Switches

Standards and approvals

All CE marked Logic Plus dimmer switches comply with the EC Low Voltage Directive: 73/23/EEC, Electromagnetic Compatibility Directive 89/336/EEC

They also comply with BS EN 60669-2-1 and BS EN 55015

Non-UK dimmer switches see note below*



Technical specification

Electrical

Mains Supply Voltage:
230V a.c. (Nominal)
220V a.c. (Nominal, Non-UK)
127V a.c. (Nominal, Non-UK)

Mains Supply Voltage Range:
216V a.c. to 253V a.c.
200V a.c. to 250V a.c.
120V a.c. to 134V a.c.

Mains Supply Frequency:
50Hz \pm 3Hz
60Hz \pm 3Hz

Type of Loads:

Standard Dimmers:
Fused GLS Tungsten Filament lamps only to BS EN 60064: 1996 and BS EN 60432-1: 2000, rated at 230/240V

Intelligent Dimmers:
Fused GLS Tungsten Filament lamps to BS EN 60064: 1996 and BS EN 60432-1,2 rated at 230/240V. Dimmable wire wound or electronic Low Voltage Transformers of good quality. Can also be used with good quality mains voltage halogen lamps incorporating GU10 bases. Please check with lamp manufacturer to determine suitability.

Note: Transformer must be suitable for dimming using phase delay (leading edge) and NOT only phase cut (trailing edge) type of dimmers.

Warning: These dimmer switches are not suitable for use with Fluorescent Lamps or Energy Saving Lamps.

Physical

Operating temperature:
0°C to +40°C

IP rating:
IP2XD

Max. installation altitude:
2000 metres

Description

MK Dimmer Switches fall into three categories:

- 1) Standard Dimmer Switches
- 2) Intelligent Dimmer Switches
- 3) Non-UK Dimmer Switches

Standard Dimmer Switches

Dimmer Switches belonging to this category employ simpler electronic circuitry and the CE marked products make use of thermal switches to conform to the very stringent requirements of the Standard BS EN 60669-2-1, for overload protection. They are only suitable for use with normal tungsten filament lamps with internal fuses, conforming to BS EN 60064: 1996 and BS EN 60432-1 Standards and do not have any added features, e.g. soft start, ability to control dimmable transformers for low voltage, etc.

Standard Dimmer Switches are not suitable for use with transformers for Low Voltage Lighting or Fluorescent Loads, including Energy Saving Lamps.

Intelligent Dimmer Switches

Dimmer Switches belonging to this category, employ the latest, state of the art, micro-controller based electronic circuitry and use current sensing to compute the load conditions. These products show progressive reaction to overload conditions, depending on the extent of overload as shown in the table below. List numbers belonging to this category are identified by the suffix letters LV, e.g. K1501 WHI LV. All MK Intelligent Dimmer Switches employ one pole change over switches to facilitate two way switching.

MK Intelligent Dimmer Switches are not suitable for use with Fluorescent Loads, including Energy Saving Lamps.

Only one Dimmer Switch can be used in a two-way switching circuit.

40-500W CIRCUIT	40-300W CIRCUIT	COMMENTS
Overload management: 40-500W nominal 40-625W function without dimming > 625-750W dim to 68V \pm 8V r.m.s. > 750W switch off	Overload management: 40-300W nominal 40-375W function without dimming > 375-500W dim to 68V \pm 8V r.m.s. > 500W switch off	This is the min. controlled voltage

*Non-UK Dimmer Switches

Dimmer switches belonging to this category only conform to the safety parts of BS EN 60669-2-1, without conforming to the EMC requirements. Loads suitable for use with standard dimmer switches above are also suitable for use with this category of dimmer switch.

Dimmer Switches

Features

Intelligent Dimmer Switches incorporate the following advanced features

- Suitable for dimming Low Voltage Halogen lamps via good quality, fully dimmable electronic or wire-wound transformers
- Can be used with good quality mains voltage halogen lamps incorporating GU10 bases. Please check with lamp manufacturer to determine suitability
- Load current sensing:
These dimmers continuously monitor the load current to help protect against overheating in wire wound transformers and to prevent overloading of the dimmer for long term reliability
- Soft Start, which gradually increases the light output from the load over 1 to 3 seconds after switch on. The Soft Start feature is also particularly beneficial when used to dim Mains Voltage Tungsten Halogen lamps which have inherent very high inrush current at switch on

Standard Dimmer Switches

- Suitable only for use with fused GLS Tungsten Filament lamps to BS EN 60064 and BS EN 60432-1
- One way dimmer switches incorporate manual soft start
- Incorporate thermal switches for protection against overload

Dimensions (mm)

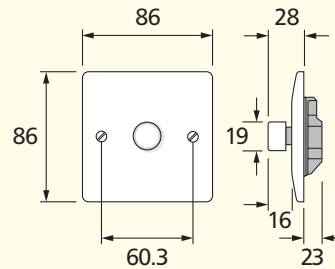

INTELLIGENT DIMMER SWITCHES

	Rating	Max No. of Transformers (total rating of all transformers must not exceed maximum VA rating of dimmer)
1 gang single dimmer	40-300W (LV and mains voltage halogen rating 40-240W/VA)	4
1 gang double dimmer	2 x 40-300W (LV and mains voltage halogen rating 2 x 40-240W/VA)	4 per dimmer
1 gang single dimmer	60-500W (LV and mains voltage halogen 60-400W/VA)	5

One-way switching

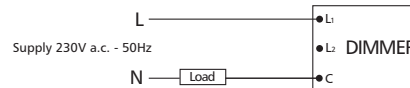

Two-way switching (only one dimmer can be used)

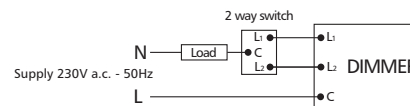

Wires must be connected to the correct dimmer terminals.
DO NOT connect earth to dimmer.

Please note the dimmer may be substituted for any of the Two-Way switches

Euro and LJU6C Data Frontplates

Standards and approvals

BS 5733: 1995

Technical specification

Dimensions

Height:	85.75mm
Width:	85.75mm (1G)
	147mm (2G)
Depth:	9mm

Aperture Dimensions (nominal)

Euro Frontplates

Height:	50mm
Width:	50mm (1G)
	100mm (2G)

LJU6C Frontplates

Height:	37mm
Width:	22mm

Features

- 1G and 2G frontplates
- Logic Plus style
- Colour matched to MK Logic Plus range
- Accept industry standard Euro or LJU6C snapfit modules
- 1G Euro frontplate accepts 2 Euro modules, (50 x 50mm aperture)
- 2G Euro frontplate accepts 4 Euro modules, (100 x 50mm aperture)
- 2G LJU6C frontplate accepts two LJU6C modules (27 x 37mm aperture)
- 1/2 module (12.5 x 50mm) blank available for Euro frontplates

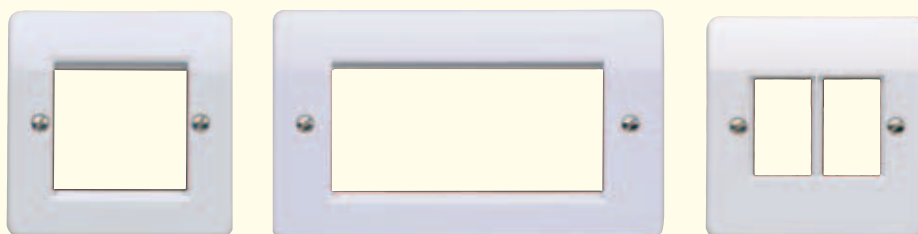

Description

Frontplates used for mounting snapfit data modules.

Dimensions (mm)

Euro Frontplates

1 Gang 2 module

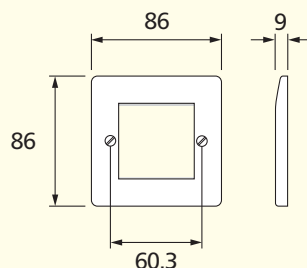

K182 WHI

2 Gang 4 module

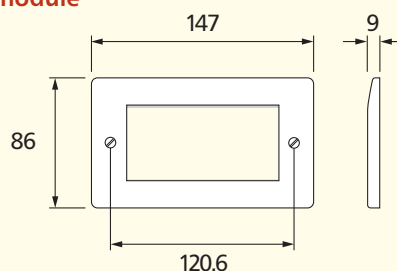

K184 WHI

LJU6C Frontplates

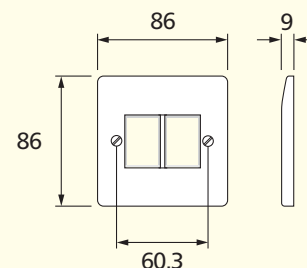

K172 WHI

3 Gang 6 module

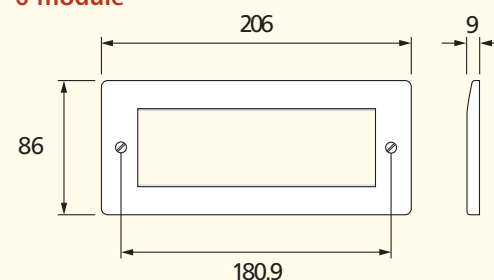

K185 WHI

Power Modules

Standards and approvals

K5830: BS 1363: Part 2: 1995

K5833: BS 546: 1950

K5831: IEC 60884-1: 2006

K5834: French National Standard

K5832: SASO 2203: 2003

NF C 61-314

Description

A range of euro modules designed to provide a variety of power options.

Technical specification

13A UK	5A UK	16A German	16A French/Belgian	15A American
Electrical	Electrical	Electrical	Electrical	Electrical
Voltage rating: 250V a.c.	Voltage rating: 250V a.c.	Voltage rating: 250V a.c.	Voltage rating: 250V a.c.	Voltage rating: 127V a.c.
Current rating: 13A	Current rating: 5A	Current rating: 16A	Current rating: 16A	Current rating: 15A
Terminal capacity: Live, neutral & earth 3 x 2.5mm ² 3 x 4mm ² 2 x 6mm ² (stranded)	Terminal capacity: Live, neutral & earth 3 x 2.5mm ² 2 x 4mm ² 2 x 6mm ² (stranded)	Terminal capacity: Live, neutral & earth 4 x 1.5mm ² 2 x 2.5mm ² 1 x 4mm ²	Terminal capacity: Live, neutral & earth 3 x 2.5mm ² 2 x 4mm ² 1 x 6mm ²	Terminal capacity: Live, neutral & earth 3 x 2.5mm ² 2 x 4mm ² 1 x 6mm ² (stranded)
Physical	Physical	Physical	Physical	Physical
Ambient operating temperature: -5°C to +40°C (not to exceed an average of more than 25°C in any 24 hour period)	Ambient operating temperature: -5°C to +40°C (not to exceed an average of more than 25°C in any 24 hour period)	Ambient operating temperature: -5°C to +40°C (not to exceed an average of more than 25°C in any 24 hour period)	Ambient operating temperature: -5°C to +40°C (not to exceed an average of more than 25°C in any 24 hour period)	Ambient operating temperature: -5°C to +40°C (not to exceed an average of more than 25°C in any 24 hour period)
IP rating: IP2XD	IP rating: IP2XD	IP rating: IP2XD	IP rating: IP2XD	IP rating: IP2XD
Max. installation altitude: 2000 metres	Max. installation altitude: 2000 metres	Max. installation altitude: 2000 metres	Max. installation altitude: 2000 metres	Max. installation altitude: 2000 metres

Dimensions (mm)

13A UK

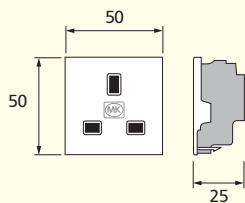

5A UK

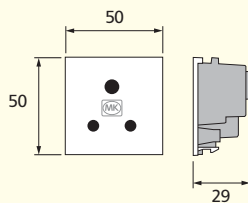

16A German

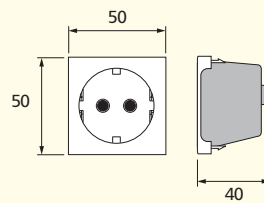

16A French/Belgian

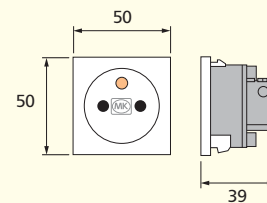

15A American

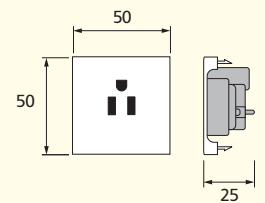

K5830

BOX TYPES
Minimum
35mm
Extra wiring space
46mm

K5833

BOX TYPES
Minimum
35mm
Extra wiring space
46mm

K5831

BOX TYPES
Minimum
46mm

K5834

BOX TYPES
Minimum
46mm

K5832

BOX TYPES
Minimum
35mm
Extra wiring space
46mm

Installation

MK socket outlets can be wall or bench mounted. Do not mount or use as a trailing socket or where they may be subject to excessive moisture or dampness.

RJ45 Data Outlets

Standards and approvals

BS EN 50173.

IEC 11801.

TIA/EIA 568A.

TIA/EIA TSB40A.



Description

Modules suitable for use in LJU6C, Euro and MK Modular frontplates in the Logic Plus range, Cat 5e/6 modules are suitable for use in structured cabling distribution systems.

Installation

- Maximum cable length 90m.
- Cable bend radii, 40mm during installation, 20mm after installation.
- Maximum pull force 8.7kg.
- Do not over tighten cable ties.
- Do not unwind the twists in the wire pairs by more than 13mm max.

BOX TYPES

Cat 6	Depth	Note
UTP	35mm	Edge/Insignia and Aspect require 46mm box depth
STP	35mm	Edge/Insignia and Aspect require 46mm box depth
Cat 5e	Depth	Note
UTP	35mm	Edge/Insignia and Aspect require 32mm box depth
STP	46mm	Edge/Insignia and Aspect require 45mm box depth

DIMENSIONS

Euro	25 x 50mm	Nominal
LJU6C	22 x 37mm	Nominal
MK Modular:		
Logic Plus	25 x 58mm	(only fit into MK modular frontplates K191/2/3/4)

Installation details and wiring diagram illustrations

TIA WIRING SCHEME COLOUR CODES:

Pin No.	568A	568B
1	WHITE / green	WHITE / orange
2	GREEN / white	ORANGE / white
3	WHITE / orange	WHITE / green
4	BLUE / white	BLUE / white
5	WHITE / blue	WHITE / blue
6	ORANGE / white	GREEN / white
7	WHITE / brown	WHITE / brown
8	BROWN / white	BROWN / white

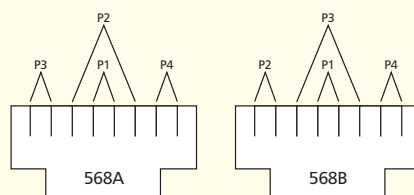

Pair 1 – BLUE/white & WHITE/blue
 Pair 2 – ORANGE/white & WHITE/orange
 Pair 3 – GREEN/white & WHITE/green
 Pair 4 – BROWN/white & WHITE/brown

Euro and LJU6C modules are to be wired as follows

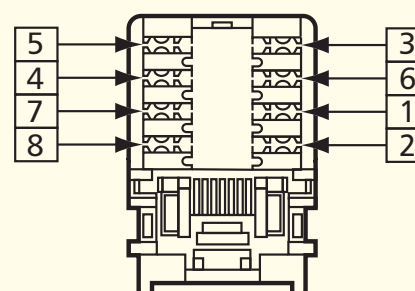

Telephone, RJ11/12, BNC Data and Blank Modules

Standards and approvals

Telephone sockets K5820 and K5821 comply with: BS 6312: 2.2,
Data sockets K5801, BS 5733:1995 (where applicable).
K5887 complies with FCC68.



Technical specification

Electrical

Cable types:

Telephone: CW1311, CW1293, CW1308, CW1316

No. of cables per termination:

Telephone: 2

RJ11/12: 1

BNC

50. impedance cable – RG58, RG141, URM43 Belden 9907

Frequency range:

BNC connector: 0 to 4GHz

Impedance:

BNC Connector: 50 Ohms nominal

Termination type:

Telephone module – IDC

BNC module – Crimped connection

Physical

Temperature range:

Ambient air –20°C to +60°C

IP rating:

IP2XD – K5820, K5821, K5801 and K5787.

IP4X – K180, K188, K186 and K170

Max. installation altitude:

2000 metres

Description

A range of telephone, data and blank modules to fit Euro and U6UC front plates. BNC Euro modules with a 500ohm crimp connector suitable for use with RG58, URM43, URM76 and Beldon 9907 type co-axial cables are also available.

Installation (Telephone socket modules)

Product performance, systems compatibility

Master Sockets: For use as the first socket outlet on a direct exchange. They contain the required surge protector (for line protection against electrical surges) and ringing capacitor.

Secondary Sockets: for use as extension sockets when connected on the same line as a Master Socket.

Installation tools required IDC Connectors (telephone & RJ45 outlets)

MK insertion tool List No. 400 or 22630.

Wire pull-out force: 10.5 Newtons when installed correctly.

Wiring regulation restrictions

Domestic Installations: The total REN (Ring Equivalent Number) value of all telephone equipment connected on a line must not exceed 4.

BOX TYPES

K5820 / K5821	16mm
K5801 / K5887 / K5787	25mm

DIMENSIONS (mm)	(Nominal)
List No.	Dimensions
K5820 / K5821 / K5801 / K188 / K5887	25 x 50
K180	50 x 50
K186	12.5 x 50
K5787/K170	22 x 37

Features

- Meet all relevant BS, OFTEL and cabling standards
- Interchangeable modules clip into frontplates
- Front fixing facilitates easy exchange of modules
- Part of a complete range of products for telephone and data processing requirements

Telephone sockets

- 100% tested before delivery
- Quick, simple and reliable IDC connectors

- Can be specified for all applications
- Fit in plaster depth boxes

Data sockets

- Latest specification for high performance systems
- Made to stringent quality assurance procedures
- Wide range of data connectors available

For information on TV Satellite and FM Modules see pages 408

BT Wiring Scheme

- 1 GREEN / white
- 2 BLUE / white
- 3 ORANGE / white
- 4 WHITE / orange
- 5 WHITE / blue
- 6 WHITE / green

Note: Main wire colour is shown in capitals

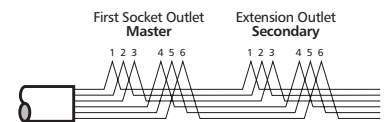
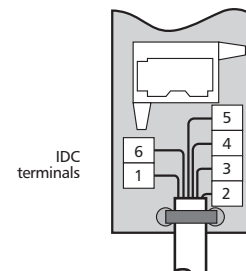

RJ11/12 Wiring Scheme

PIN NO.	STRIPPED COLOUR WIRE	SOLID COLOUR WIRE
1	WHITE / green	White
2	WHITE / orange	Black
3	BLUE / white	Red
4	WHITE / blue	Green
5	ORANGE / white	Yellow
6	GREEN / white	Blue

Note: Main wire colour is shown in capitals

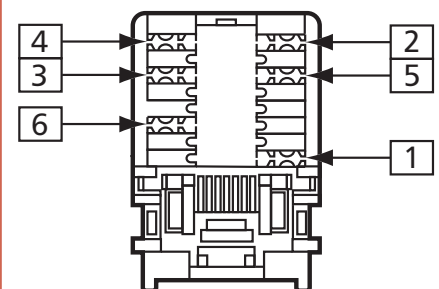

For a full range of corresponding products, see pages 48-52 in the product selector.

MK Modular Datacoms

Standards and approvals

Logic Plus Telephone and Data sockets comply with the following:

Telephone sockets K420 and K421

BS 6312: 2.2, OFTEL Approval NS/G/23/L/100005

Data sockets K190 to K194, K501

BS 5733: 1995 (where applicable)

Data sockets K545

Cat 5e performance to EIA/TIA TSB568, BS EN 50173, IEC11801

Technical specification

Electrical

Cable types:

Telephone CW1311, CW1293, CW1308, CW1316

RJ45: 20 to 26 AWG, 100 ohm Cat 5e UPT cable

No. of cables per termination (Telephone & RJ45):

Telephone: 2

RJ45: 1

BNC

50Ω impedance cable – RG58, RG141, URM43 Belden 9907

Frequency range:

BNC connector: 0 to 4GHz

Impedance:

BNC Connector: 50Ω nominal

Termination type:

RJ45 & telephone module – IDC

BNC module – Crimped connection

Physical

Temperature range:

Ambient air -20°C to +60°C

IP rating:

IP2XD

Max. installation altitude:

2000 metres



Description

A unique modular system in the distinctive Logic Plus style comprising a range of socket modules for Data and Telephone use, with 4 matching frontplates capable of accepting combinations of interchangeable modules. The 'clip-in' design provides a high degree of versatility, making the system ideal for use in all commercial and industrial applications.

Features

- Meet all relevant BS, OFTEL and cabling standards
- Interchangeable modules clip into frontplates
- Front fixing facilitates easy exchange of modules
- Part of a range of products for telephone and data processing requirements

Telephone sockets and frontplates

- Quick, simple and reliable IDC connectors
- Can be specified for all applications
- Fit in plaster depth boxes

Data sockets and frontplates

- Cat 5e specification performance
- Made to stringent quality assurance procedures

BOX TYPES

Where there is more than one module in a frontplate, the depth of the box is determined by the module with the deepest back projection.

Ref.	Min. box depth mm	Flush box List No.	Surface box List No.
K420	16	3995 ZIC	K2160 & 2161 WHI
K421	16	3995 ZIC	K2160 & 2161 WHI
K190	16	3995 ZIC	K2160 & 2161 WHI
K501	16	3995 ZIC	K2160 & 2161 WHI
K545			
(min.)	16	3995 ZIC	K2160 & 2161 WHI
(recommend)	25	861 & 862 ZIC	K2140 & 2142 WHI

Dimensions – Data and TV modules (mm)

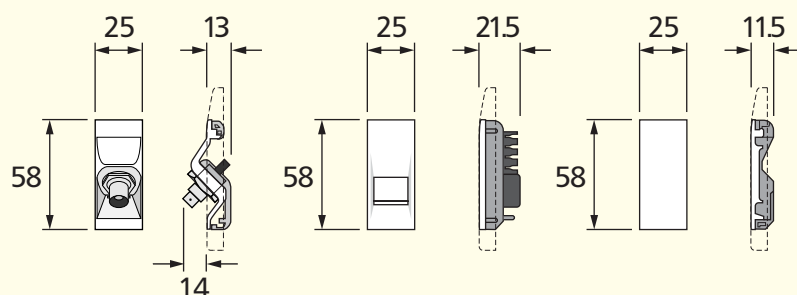

K501 WHI

K420 / K421 /
K545 WHI

K190 WHI

MK Modular Datacoms

Dimensions – Modular frontplates (mm)

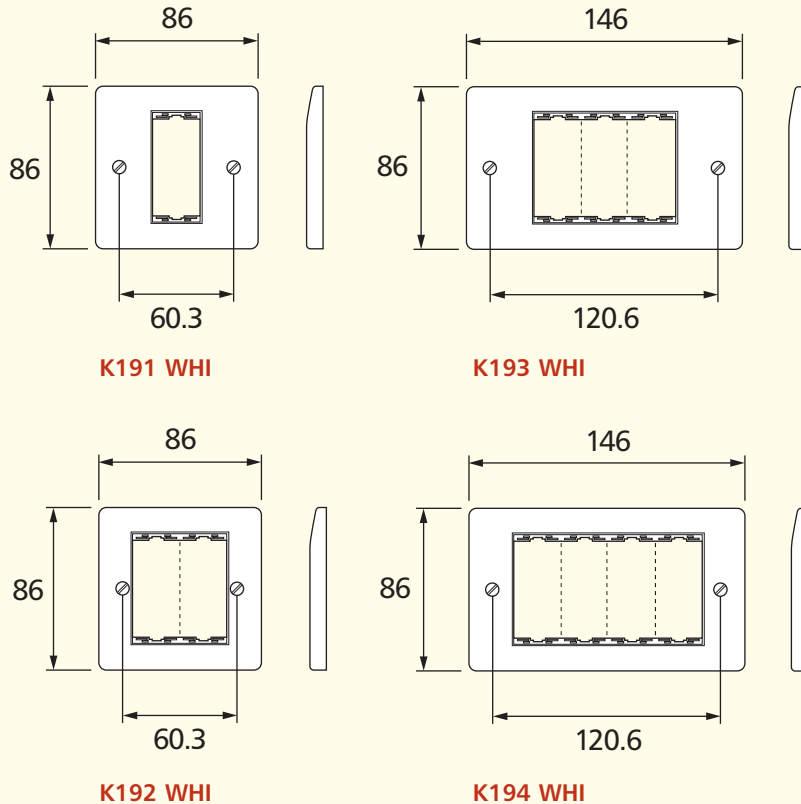

Installation (Data sockets)

RJ45 modules

In order to maintain Category 5e performance, install cabling in accordance EIA/TIA or ISO General Cabling Standards.

Installation (Telephone socket modules)

Product performance, systems compatibility

Master Sockets: For use as the first socket outlet on a direct exchange. They contain the required surge protector (for line protection against electrical surges) and ringing capacitor.

Secondary Sockets: for use as extension sockets when connected on the same line as a Master Socket.

Installation tools required IDC Connectors (telephone & RJ45 outlets)

MK insertion tool List No. 400 or 22630.

Wire pull-out force: 10.5 Newtons when installed correctly.

Wiring regulation restrictions

Domestic Installations: The total REN (Ring Equivalent Number) value of all telephone equipment connected on a line must not exceed 4.

Industrial and commercial installations: MK telephone sockets are suitable in all situations after the PBX/PABX has been installed by a recognised installer. For key systems and other 'special' systems, the manufacturer's instructions should be referred to.

Safety information

None of the above products should be installed into the same fixing or mounting boxes as mains rated equipment or cable.

Note: For BT and RJ45 wiring scheme diagrams see page 402.

Cable management

Logic Plus Modular Data and Telephone Sockets can be mounted in a variety of MK trunking systems. See main catalogue for further details.

RJ11 Wiring Scheme

PIN NO.	STRIPPED COLOUR WIRE	SOLID COLOUR WIRE
1	WHITE / green	White
2	WHITE / orange	Black
3	BLUE / white	Red
4	WHITE / blue	Green
5	ORANGE / white	Yellow
6	GREEN / white	Blue

Note: Main wire colour is shown in capitals

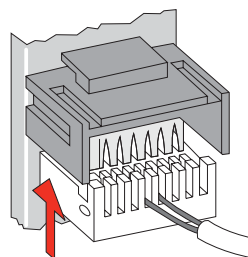
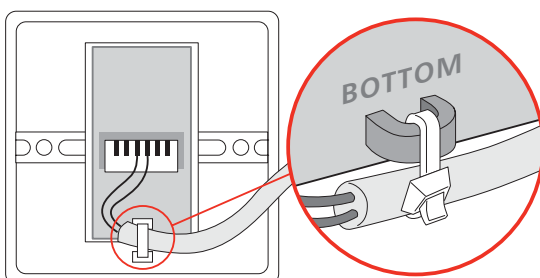
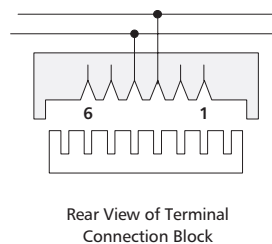

Telephone, TV/FM and Satellite Socket Outlets

Standards and approvals

Logic Plus Telephone and TV sockets comply with the following:

Telephone sockets K422 and K427

BS 6312: 2.2, BS 5733: 1995 (where applicable).

K4817: BS 5733: 1979 (where applicable) and FCC68.

TV sockets K3520, K3521 and K3523

BS 3041: Part 2: 1977/IEC 169-2: 1977, BS5733: 1995 (where applicable) and IEC65, Cls 10.1, 10.3.

TV sockets K3525

BS 5733: 1995 (where applicable).



Description

A part of the very wide range of products in the distinctive Logic Plus style to meet the latest technical requirements and the standards applicable to modern technology in the installation of telephone and television equipment. The master and secondary telephone sockets K422 and K427 comply with relevant approvals for direct and indirect connections between a termination point of a public telecommunications system and any piece of approved telecommunications apparatus. For applications requiring twin or dual telephone outlets, refer to 'Modular Data and Telephone Sockets'.

Logic Plus Telephone and TV sockets will fit in plaster depth boxes (except for RJ11).

The F-type Satellite Socket may be used for connection of CATV, MATV and satellite TV installations.

Digital TV outlets are available.

Technical specification

Electrical

Telephone sockets, cable specification:
CW1311, CW1293, CW1308, CW1316
No. of cables per termination: 2

Re-usability:
>9 reterminations (should not be reterminated with smaller diameter wire)

TV sockets:
Cable specification: CT 100 or equivalent
Any standard low-loss TV co-axial cable:
Outside 4-8mm diameter,
inner conductor 0.5-2mm diameter

Insertion loss:
Insertion loss data available on request

'F' Type satellite socket (K3525), cable specification:
Co-axial cable: inner core diameter – 0.5-1.2mm

RJ11 (K4817), Cable specification:
Capable of taking 0.08 to 0.65mm² solid or stranded cable

Physical

Ambient air:
–20°C to +60°C

IP rating:
IP2XD

Max. installation altitude:
2000 metres

Features

- Single screw termination on TV outlets
- Protected, fully enclosed PCBs
- Meet all relevant BS requirements
- Attractive new easy-clean Logic Plus styling
- Quick, simple and reliable terminal connection
- IDC connectors on telephone outlets
- Part of a complete range of products for telephone, television and data processing requirements
- Angled connector on TV outlets
- Sockets fit in plaster depth boxes (except K4817)

Telephone, TV/FM and Satellite Socket Outlets

Dimensions (mm)

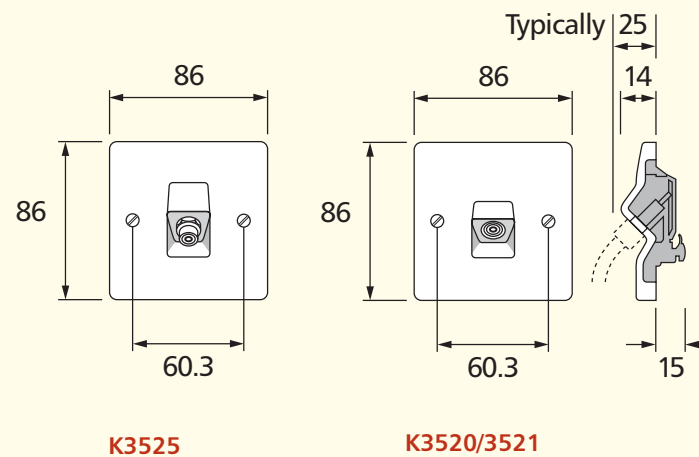
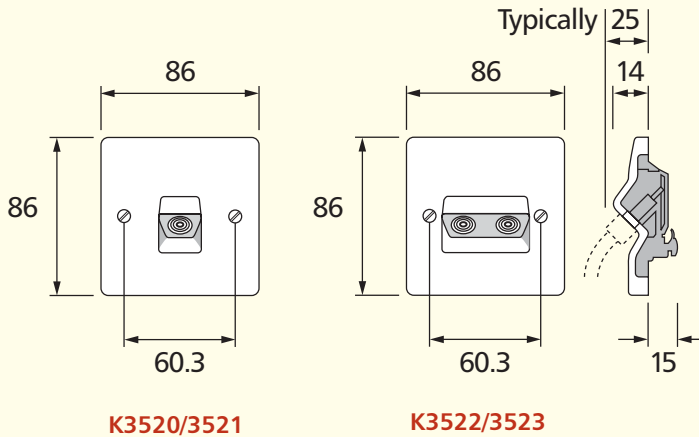

Sectional drawings show the furthest projections from the back of the frontplate (wall surface), including a typical coaxial connector in the case of TV sockets. All units will fit in 16mm plaster depth boxes except for K4817 (Western Telecom socket).

BOX TYPES		
	Flush	Surface
1 gang	861 ZIC	K2140 WHI

Installation (Telephone sockets)

Product performance, systems compatibility

Master Sockets: for use as the first socket outlet on a direct exchange or PABX line. They contain surge protector (for line protection against electrical surges) and ringing capacitor.

Secondary Sockets: For use as extension sockets when connected on the same line as a Master Socket.

Installation tools required

MK IDC insertion tool List No. 400 or 22630 (not supplied with product).

Wiring regulation restrictions

Domestic installations: Any number of MK sockets may be installed thereafter, with a total REN (Ring Equivalent Number) value of all telephone equipment connected on a line not exceeding 4.

BT Wiring Scheme

- 1 GREEN / white
- 2 BLUE / white
- 3 ORANGE / white
- 4 WHITE / orange
- 5 WHITE / blue
- 6 WHITE / green

Note: Main wire colour is shown in capitals

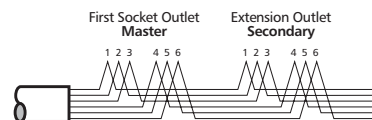
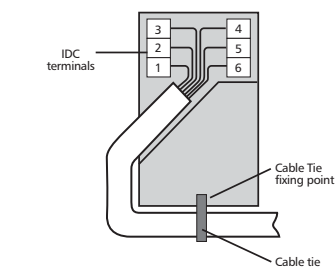

Telephone, TV/FM and Satellite Socket Outlets

Installation (TV sockets)

Product performance, systems compatibility

Isolated Outlets are intended for use where safety isolation (rated at 2000V ac) is required to provide protection against faults occurring within any mains powered product used on different parts of the distribution system. They are not suitable for use in systems where DC signals are passed through the socket, (e.g. where masthead/headend equipment is controlled by receiver/decoder equipment).

Diplexer Outlets are used in distribution systems where both TV and FM band signals are combined on a single aerial download. The filtering in the diplexer separates the appropriate signals and feeds them through to the relevant output connection port.

Cable Routing and Use of Cable Clamp

Sharp bends in the cable must be avoided during installation. The single TV/FM socket is fitted with a cable clamp that can be fixed on either side of the termination position to facilitate this.

When tightening the screening braid clamps ensure that the cable is firmly gripped and that the inner insulation is not squashed flat beyond a slight oval shape.

Safety Information

TV outlets or modules must not be installed in the same enclosure as equipment rated in excess of 50V, (e.g. mains rated 13A sockets or switches).

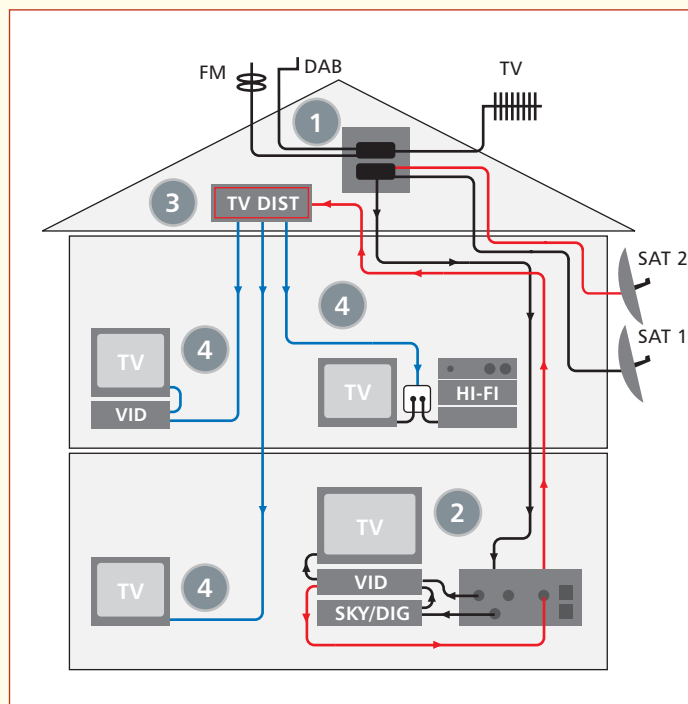

Method of installation of TV and FM aerial connection by using MK co-axial socket outlet and only one download.

Conventional distribution system for TV and FM signals using a single aerial download.

- 1 The signals from the TV and FM aerials and the satellite dish are combined together using two products. The first combines the TV and FM signals and the second adds the Sky signal to the TV/FM signal and provides a DC control path to power the LNB unit on the satellite dish. (These products are not supplied by MK).

The single aerial down lead feeds into the triplexer (black lines in wiring diagram).

- 2 The separated satellite signal is then fed to the decoder. The decoded satellite signal is then fed into the VCR along with the TV signal from the Triplexer. The output signal from the VCR then feeds into the TV and also back to the single outlet and onto the distribution amplifier (black lines in wiring diagram).
- 3 The single cable back-feed then feeds back to the input of a multi way distribution amplifier, (typically located in the loft or garage) (red lines in wiring diagram).
- 4 Each individual output from the distribution amplifier is then fed to the individual rooms in the house to a standard TV (single or diplexer) outlet to which the TV/VCR and/or Hi-Fi can be connected (blue lines in wiring diagram).

Digital TV, Radio and Telephone Outlets

Standards and approvals

All Logic Plus TV Outlets comply with BS 5733 and BS EN 50083 where applicable.

Also IEC 169-2, BS EN 60169-24 and BS 6312 part 2

Modular products are Euro compatible.

Technical specification

Single Outlets

TV/FM IEC Male or Female DC-950MHz
SAT F-Type DC-1.75GHz

Diplexer and Triplexer products

TV

Diplexer: DC-68.5MHz, 174-862MHz
Triplexer: DC-68.5MHz, 174-862MHz

FM

Diplexer: 87.5-108MHz
Triplexer: 87.5-108MHz

SAT

Diplexer: n/a
Triplexer: DC-200kHz, 950-2400MHz

TV/FM/DAB/SAT products for digital radio

TV

Diplexer: 470-862MHz
Triplexer: 470-862MHz

FM/DAB

Diplexer: 87.5-230MHz
Triplexer: 87.5-230MHz

SAT or SAT1

Diplexer: n/a
Triplexer: 950-2400MHz

SAT2

Diplexer: n/a
Triplexer: DC-2300MHz



Description

There are two ranges of diplexer and triplexer products, an established range suitable for VHF TV, and a range suitable for digital radio (DAB).

Diplexer modules are for connecting to a single co-axial aerial down lead carrying combined TV and FM signals. The filtering in the diplexer splits out the appropriate signal and feeds it to the relevant output connection. A DC control path is provided in the TV signal path through the diplexer.

Triplexer modules are for connecting to a single co-axial aerial down lead carrying combined TV, FM and SAT signals. The filtering in the triplexer splits out the appropriate signal and feeds it to the relevant output connection. A DC control path is provided in the SAT signal path through the triplexer.

The quad outlet contains a triplexer together with a separate satellite output, for use with Sky+, or more complex installations.

Telephone secondary outlets are provided on some products for connection of telephone or for interactive TV applications.

Features

- Non Isolated
- Fully screened
- Earth terminal provided on TV modules
- Selected products with supplementary TV outlet for back-feed for further distribution
- Selected products with BT secondary outlets for interactive TV applications

Cable management

Logic Plus TV outlets can be mounted in a variety of MK trunking systems.

BOX TYPES

	Flush	Flush (for Extra wiring space)	Surface Insulated	Surface Metal
1 gang	861 ZIC	866 ZIC	K2140 WHI	K2211 ALM/K2213 ALM
2 gang	862 ZIC	886 ZIC	K2142 WHI	K2212 ALM/K2214 ALM

Minimum recommended box depth 32mm

Note: Edge/Insignia mounted modular products require 45mm box

Digital TV, Radio and Telephone Outlets

Dimensions (mm)

1 gang (monobloc) dimensions (mm)

2 gang (monobloc) dimensions (mm)

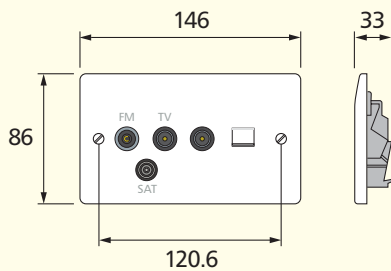

Installation

- When installing the TV co-axial cable ensure that all cable bends are smooth so that the inner insulation is not crushed or squashed, otherwise the TV signal quality may be affected.
- Not suitable for loop-in loop-out installations.
- Use CT100 cable (or equivalent).

TV Co-axial cable stripping details

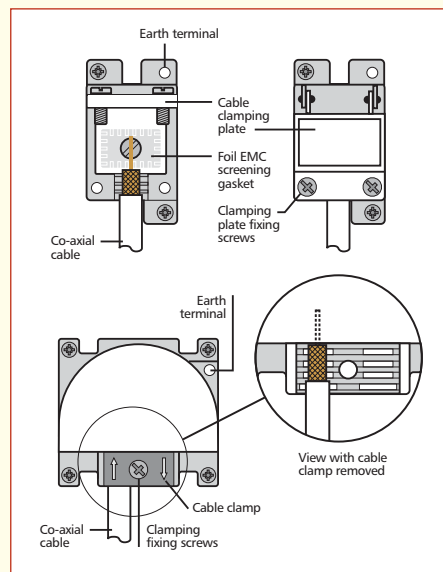
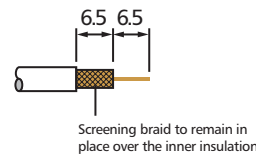

2, etc).

In the event that the earth terminal is required to be used, the installer must ensure that a suitable earth conductor is present to connect to the earth terminal. (In the case of 2G products both TV modules should be earthed).

In the event that the earth terminal is required to be used, the installer must ensure that a suitable earth conductor is present to connect to the earth terminal. (In the case of 2G products both TV

BT Wiring Scheme

- 1 GREEN / white
- 2 BLUE / white
- 3 ORANGE / white
- 4 WHITE / orange
- 5 WHITE / blue
- 6 WHITE / green

Note: Main wire colour is shown in capitals

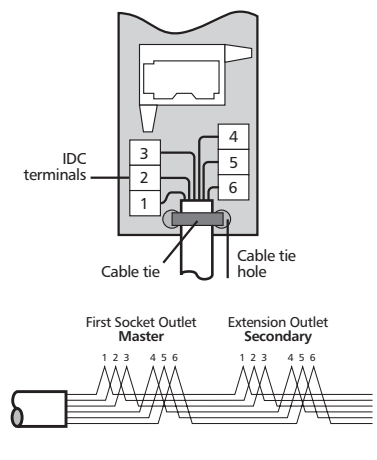

modules should be earthed).

BT Outlet Connection

Carefully strip 50mm of the BT cable outer sheath to expose the inner insulated conductors. Using the insertion tool supplied, (MK List no. 400) carefully push each lead into the appropriate IDC terminals according to the wiring colour code stated in the BT Wiring Scheme diagram.

Pins 1 and 6 are frequently unused, 4 wire cable may be used in these installations.

If an existing installation uses a different wiring colour code system, this should be retained on any new or extended installation.

Additional secondary extension outlets should be wired in parallel with the existing installation via the IDC terminals, (i.e. pin 1 to pin1, pin 2 to pin

Grid Plus Front Plates

Standards and approvals

BS 5733: 1995

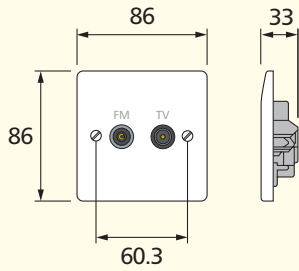

Description

Grid Plus is a comprehensive modular switching and monitoring system ideal for a variety of applications within the commercial, public and domestic sectors.

Dimensions (mm)

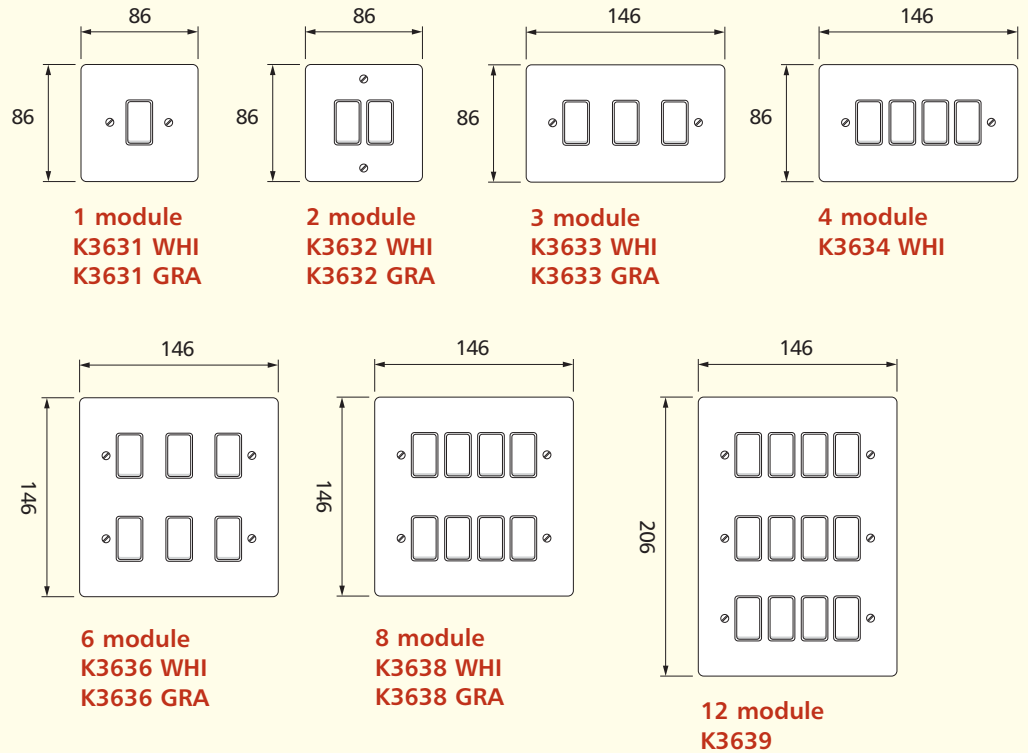

Accessories

SURFACE MOUNTING BOXES									
	16mm Moulded	30mm Moulded	32*mm Moulded	38mm PVC	40mm Moulded	41mm Steel	41*mm Steel	48*mm Steel	55mm Steel
1 gang Sockets (13A)		K2140	K2181	K2025	K2031	K2211 ALM	K2213 ALM		
2 gang Sockets		K2142	K2183		K2172	K2212 ALM	K2214 ALM	K5400	
3 gang Sockets		K2153	K2185						
2A Round Pin Sockets		K2140	K2181			K2211 ALM	K2213 ALM		
5A/15A Round Pin Sockets		K2140	K2181			K2211 ALM	K2213 ALM		
RCD Sockets					K2172	K2212 ALM	K2214 ALM	K5400	
Filtered Sockets					K2172	K2212 ALM	K2214 ALM	K5400	
Connection Units		K2140	K2181	K2025	K2031	K2211 ALM	K2213 ALM		
20A DP Switches		K2140	K2181	K2025	K2031	K2211 ALM	K2213 ALM		
K5105 32A DP Switch		K2140	K2181	K2025	K2031	K2211 ALM	K2213 ALM		
K5205, K5215 (CK & SH)					K2172	K2212 ALM	K2214 ALM		
K5230								K5400	
K5060, K5061					K2172	K2214 ALM		K5400	
K700		K2140	K2181	K2025		K2211 ALM	K2213 ALM		
K701					K2172				
1, 2 & 3 gang Switches	K2160	K2140	K2181	K2025	K2031	K2211 ALM	K2213 ALM		
4 & 6 gang Switches	K2161	K2142	K2183		K2172	K2212 ALM	K2214 ALM	K5400	
1 gang Architrave Switch	K2151								
2 gang Architrave Switch	K2152								
Dimmers using Pattress K1501, K1511, K1531, K1532	K2160								
K1521, K1534, K1533, K1535	K2160								
Dimmers not using Pattress K1501, K1511, K1531, K1532		K2140	K2181	K2025	K2031				
K1521, K1534, K1533, K1535		K2140	K2181	K2025		K2211 ALM	K2213 ALM		
K191, K192		K2140 ■	K2181	K2025		K2211 ALM	K2213 ALM		
K193, K194		K2142 ■	K2183			K2212 ALM	K2214 ALM	K5400	
Data/Telecom Plates	K2160	K2140	K2181	K2025		K2211 ALM	K2213 ALM		

■ Dependent upon modules used

* With conduit entry knockouts

NOTE: the size of cable should be taken into consideration when choosing box depth

Accessories

FLUSH MOUNTING BOXES								
	16mm	25mm*	27mm*	35mm*	45mm	46mm*	47mm*	55mm
1 gang Sockets (13A)		861 ZIC		866 ZIC	K2061	877 ZIC		
2 gang Sockets		862 ZIC		886 ZIC	K2062		878 ZIC	
3 gang Sockets		K863						
2A Round Pin Sockets	3995 ZIC	861 ZIC		866 ZIC	K2061	877 ZIC		
5A/15A Round Pin Sockets		861 ZIC		866 ZIC	K2061	877 ZIC		
RCD Sockets				886 ZIC	K2062		878 ZIC	
Filtered Sockets				886 ZIC	K2062		878 ZIC	
Connection Units				866 ZIC	K2061	877 ZIC		
20A DP Switches				866 ZIC	K2061	877 ZIC		
K5105 32A DP Switch				866 ZIC		877 ZIC		
K5205, K5215 (CK & SH)				886 ZIC	K2062		878 ZIC	
K5012								K5120 ALM
K5045					K2061	877 ZIC		
K5060, K5061				886 ZIC	K2061		878 ZIC	
K5011								K5120 ALM
K700		861 ZIC		866 ZIC	K2061	877 ZIC		
K701							878 ZIC	
1, 2 & 3 gang Switches	3995 ZIC	861 ZIC		866 ZIC	K2061	877 ZIC		
4 & 6 gang Switches		862 ZIC		886 ZIC	K2062			
1 gang Architrave Switch			3921 ZIC					
2 gang Architrave Switch			3922 ZIC					
Dimmers using Pattress K1501, K1511, K1531, K1532	3995 ZIC							
K1521, K1534, K1533, K1535	3995 ZIC						878 ZIC	
Dimmers not using Pattress K1501, K1511, K1531, K1532		861 ZIC		866 ZIC	K2061	877 ZIC		
K1521, K1534, K1533, K1535		861 ZIC			K2062	877 ZIC		
K191 & K192		861 ZIC ■		866 ZIC ■	K2061	877 ZIC ■		
K193 & K194		862 ZIC ■		886 ZIC ■	K2062		878 ZIC ■	
Data/Telecom Plates		861 ZIC		866 ZIC	K2061	877 ZIC		

■ Box supplied with accessory

■ Dependent upon modules used

* With conduit entry knockouts

NOTE: the size of cable should be taken into consideration when choosing box depth



Edge 1 gang Freeform Design – brushed stainless steel

Available on a worldwide basis, the MK Design Service is supported by a dedicated team to ensure the seamless delivery of your chosen products.

Visit www.switchonmk.com for more information.